



K9000 2.0 Operators Manual



© Copyright 2016, Tru Blu Dog Wash, All rights reserved. K9000 2.0® is a registered trademark of Tru Blu Dog Wash.





© Copyright 2016, Tru Blu Dog Wash, All rights reserved. K9000 2.0® is a registered trademark of Tru Blu Dog Wash.

All requests and enquiries regarding the use of, and availability of this manual are to be directed to:

Tru Blu Dog Wash
Factory No. 1
34 Caramut Road
Warrnambool
Victoria 3280
Australia

Tel: +61 (0)3 5562 9088
Fax: +61 (0)3 5562 9022
Email: info@trubludogwash.com.au
Website: www.trubludogwash.com.au
www.findadogwash.com

Explanation of symbols used in this manual

	Warning
	Tip
	Important - Take note
	European Conformity
	Regulatory Compliance Mark

Date	Summary of Changes	Sections Changed/Added	Author/s	Version
27/10/2017	New Manual		Phil Worrell	1.0
11/12/2018	K9000 ECU Upgrade	All parts Section 10	Phil Worrell	2.0
13/12/2018	New EJ Exploded view diagram	4.1.4	Phil Worrell	
08/04/2019	New videos added	13.2	Phil Worrell	
22/04/2020	New ES pump & Safety re open wounds, Yearly flushing of pumps etc. and amend video reference to website New MSDS Fido's Shampoo	12.1, 13, section 4 various and 13.2 & 14.1	Phil Worrell	3.0

Version	3.0
Status	Published
Date	09/06/2020
Author/s	Phil Worrell
Build Approver	Darryn Polack
Sales Approver	Dale Beaton

Contents

1	K9000 2.0 Inspection and Acceptance on Delivery:	3
1.1	K9000 2.0 System Specifications	4
2	Installation:	5
2.1	Levelling and Positioning the K9000 2.0	5
2.2	Connecting the Water Supply and Waste connection to the K9000 2.0	6
2.2.1	Connecting the Water Supply	6
2.2.2	Hot Water	7
2.2.2.1	Site Supplied Hot Water	7
2.2.2.2	On Board Instantaneous Hot Water Unit	7
2.2.3	On Board Hot Water Storage Unit - Breaker	8
2.2.4	Connecting the Waste	9
2.3	Connecting the Power – For Your Electrician	10
2.4	Completing the Installation	11
3	Commissioning the Unit	11
4	Main Board Components	12
4.1	K9000 2.0 Main Board with Iwaki EJ Series Pumps	12
4.1.1	Control Module	13
4.1.2	Product Dosing Pump Factory Settings (Iwaki EJ & ES Series Pumps)	14
4.1.2.1	Iwaki EJ Series Pump	14
4.1.2.2	Iwaki ES Series Pump	15
4.1.3	Bleeding Product Dosing Pumps (Iwaki – EJ or ES Series Pumps)	16
4.1.4	Iwaki Dosing Pump Exploded Views	17
4.1.4.1	Iwaki Dosing Pump – EJ Series Exploded View	17
4.1.4.2	Iwaki Dosing Pump – ES Series Exploded View	18
4.2	Approved Products	19
5	Cash Box Components	20
5.1	Top Section of Cash Box	20
5.2	Bottom Section of Cash Box	21
5.3	Coin Acceptor – coin activation	22
5.4	Coin Acceptor – Removal	24
5.5	Coin Acceptor Cleaning	25
6	Note Acceptor (Mei)	26
6.1	Note Acceptor Fault Codes	26
6.2	Note Acceptor Removal	27
6.3	Note Acceptor Cleaning	28
7	Temperature Valve	29
7.1	Temperature Adjustment	29

8	Dryer	30
8.1	By-Pass Dryer - Operation (Summer/Winter).....	30
8.2	Heated Dryer - Operation (Heat Settings).....	31
8.3	Dryer Hose Connection	32
9	Override Key (Wash down Key)	33
10	Dog Wash K9000ECU Board Operating & Service Menu Programming Instructions .	34
10.1	Service Menus	34
10.1.1	Service Menu 1: PROGRAM MODE	35
10.1.2	Service Menu 2: TEST	36
10.1.3	Service Menu 3: AUDIT.....	37
10.1.4	Service Menu 4: INFO.....	37
10.1.5	Service Menu 5: IMPORT	37
10.1.6	Service Menu 6: EXPORT.....	37
11	Floor Lifting Tool.....	38
12	Operator Maintenance	39
12.1	Maintenance Schedule.....	39
12.2	External Maintenance Items	42
12.3	Dryer Maintenance.....	43
12.4	Cleaning.....	44
13	General Information	47
13.1	Canine parvovirus	47
13.2	Instruction “How to Videos”	47
14	MSDS Attachments	48
14.1	Material Safety Data Sheet (MSDS) Fido’s Everyday Shampoo.....	48
14.2	Material Safety Data Sheet (MSDS) Fido’s Crème Conditioner	48
14.3	Material Safety Data Sheet (MSDS) Fido’s Fre-Itch Rinse Concentrate	48
14.4	Material Safety Data Sheet (MSDS) Fido’s Hydrobath Flush.....	48
15	Maintenance Record.....	49

1 K9000 2.0 Inspection and Acceptance on Delivery:

Inspect the K9000 2.0 on arrival and prior to unwrapping to ensure there is no travel damage. If there is any damage, please contact Tru Blu Dog Wash before accepting delivery.



Caution should be taken when the K9000 2.0 has been delivered and is being unloaded. The K9000 2.0 weighs approx. 275kg. Ensure a qualified operator of the unloading equipment is used to lift or move the K9000 2.0 Dog Wash.

The K9000 2.0 (Within Australia) is first bubble wrapped and then wrapped in black plastic cargo wrap. It is secured to the pallet with a tie down strap over the cabinet and 6 screws. Position the K9000 2.0 while on the pallet near its final location. Take caution removing the plastic and bubble wrap avoid using a knife as it may scratch the stainless steel or decals. With a screw gun remove the screws from the feet and the tie down strap.



A second inspection should be undertaken to ensure no damage has occurred during travel.



It is recommended that the front kicker plate be removed prior to installation and handling as this will allow safer lifting and the required access during installation. *Care should be taken not to damage the plumbing fittings during lifting and positioning of the unit.*



The kicker plate allen key bolt positions (2 at each end)

A 4mm allen key is used to remove the kicker plate.

It is also recommended that the white film protecting the unit is not removed until after install as this will help prevent any installation damage.

1.1 K9000 2.0 System Specifications

SYSTEM WITHOUT ON BOARD HOT WATER UNIT		
Power	240V	15 AMP (with heated dryer)
Power	240V	10 AMP (without heated dryer)
WATER Inlet Pressure (Min) 40psi / 275kpa	Hot	½" Ball valve
	Cold	½" Ball valve
WATER Inlet Pressure (Max) 72psi / 500kpa	Hot	½" Ball valve
	Cold	½" Ball valve
COLD WATER Inlet temperature	Minimum	5 Degrees Celsius
	Maximum	30 Degrees Celsius
HOT WATER Inlet temperature	Minimum	55 Degrees Celsius
	Maximum	65 Degrees Celsius
Factory Set water temperature	35 Degrees Celsius at wash gun	
WATER Maximum Operating Pressure 50psi / 350kpa	Factory set via water regulator	
FILTRATION	Primary	Stainless steel mesh filter
	Secondary	Vinidex DBA Lic. No. WMKA20071
Back Flow Prevention Device	Connections to be protected by a "high hazard" backflow prevention device. i.e. "RPZ" or Registered "Air-GAP" Recommended Watts 009M3-AUS RP 15 or 20mm AS2845.1 Lic WMKA1335	
WASTE	50mm DIA Outlet as well as, a minor trade waste application to be made to the local water regulator (Contact your local water authority trade waste division)	
SYSTEM WITH ON BOARD HOT WATER UNIT		
Power Hot Water Tank	240V	32 AMP (with hot water storage tank)
Power Instant Hot Water	240V	40 AMP (with instant electric hot water service)
WATER Inlet Pressure (Min) 40psi / 275kpa	Cold	½" Ball valve
	Cold	½" Ball valve
WATER Inlet Pressure (Max) 72psi / 500kpa	Cold	½" Ball valve
	Cold	½" Ball valve
COLD WATER Inlet temperature	Minimum	5 Degrees Celsius
	Maximum	30 Degrees Celsius
Factory Set water temperature	35 Degrees Celsius at wash gun	
WATER Maximum Operating Pressure 50psi / 350kpa	Factory set via water regulator	
FILTRATION	Primary	Stainless steel mesh filter
	Secondary	Vinidex DBA Lic. No. WMKA20071
Back Flow Prevention Device	Connections to be protected by a "high hazard" backflow prevention device. i.e. "RPZ" or Registered "Air-GAP" Recommended Watts 009M3-AUS RP 15 or 20mm AS2845.1 Lic WMKA1335	
WASTE	50mm DIA Outlet as well as, a minor trade waste application to be made to the local water regulator (Contact your local water authority trade waste division)	
Tundish	Required for hot water relief pipe	
DIMENSIONS / WEIGHT		
Dimensions	Length 2150mm / Height 1850mm / Depth 600mm	
Weight	K9000 2.0 - 285kg	K9L & Groom Easy - 225kg
APPROVALS		
Risk assessment performed by IAPMO (NATA accredited laboratory)		
CE conformity with the following European Union Directives: EMC Directive 2004/108/EC & Low Voltage Directive 2006/95/EC		
IEC 61000-6-3:2006 Electromagnetic compatibility (EMC) – Part 6.3: Generic standards – Emission standard for residential, commercial and light-industrial environments		
AS/NZS 60335.2.75:2005 + Admt 2009 in relation to vending machines AS 60204.1:2005 'Safety of machinery – Electrical equipment of machines, General Requirements'		
IEC 61000-6-1: 2005 Electromagnetic compatibility (EMC) Generic standards. Immunity for residential, commercial and light-industrial environments.		
ATS 5200.101:2005 – Strength of Assembly		

2 Installation:

The K9000 2.0 Dog Wash can be installed either indoor or outdoor.

2.1 Levelling and Positioning the K9000 2.0

The K9000 2.0 needs to be placed in a level horizontal position to operate correctly. There are 4 adjustable feet and 2 mounting feet, place a level along the back of the K9000 2.0 and adjust the feet according to get the K9000 2.0 Level, place the level along the top of the cabinet running back to front to make sure it is not tilting forward or backwards.

Verify all door margins and open and close each door to ensure they open and close freely



ENSURE all doors open and close freely before securing the K9000 2.0!

Once the K9000 2.0 is level, use the supplied spacer washes and anchor screws to secure the K9000 2.0 to the ground.



2.2 Connecting the Water Supply and Waste connection to the K9000 2.0.



Before connecting the K9000 2.0L to water and waste ensure local regulations are considered. Some sites may require an additional back flow prevention device. Local regulations may also require sites to use copper pipes for waste.

2.2.1 Connecting the Water Supply

Flush the pipes prior to connecting to the K9000 2.0. Maximum allowable water pressure is 0.5Mpa. (72 psi / 500Kpa).

The picture at left shows the hot and cold-water entry points for a K9000 2.0 without an on-board hot water unit. While the picture on the right shows the water entry point for a K9000 2.0 with an on-board hot water unit.

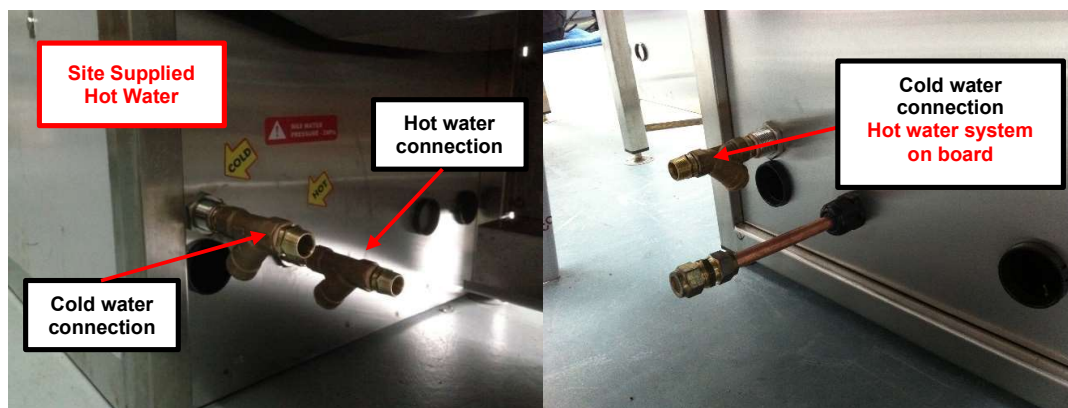

Once connected the regulator can be adjusted to ensure the K9000 2.0 has water pressure of between 20 & 30 psi when the pressure gun is in use and between 40 & 50 psi when pressure gun is not being utilised.

To verify the pressure when the gun is not being utilised you need to view the gauge at the moment the pressure gun is turned off as it will give a true indication of the psi prior to resetting to the hold psi of approximately 40psi.

- The psi verification can be done with the override key and a wash setting of stop or with money/token and the rinse setting selected.

If adjustment required, you will need adjust the regulator. The regulator is adjusted using a screw driver, where pressure needs to be increased turn the screw anticlockwise and to decrease pressure turn in a clockwise direction.

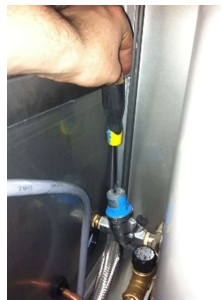

2.2.2 Hot Water

Hot water can be sourced from the site or the dog wash can include an on-board hot water service. The on-board hot water service can be either an instantaneous or 50 litre storage unit.

2.2.2.1 Site Supplied Hot Water

Shown below is a K9000 2.0 that was installed at a site that supplied HOT water, and as such the unit did not require to have an on-board hot water service.

**Please consult with Tru Blu Dog Wash to ensure your existing hot water supply is adequate.*

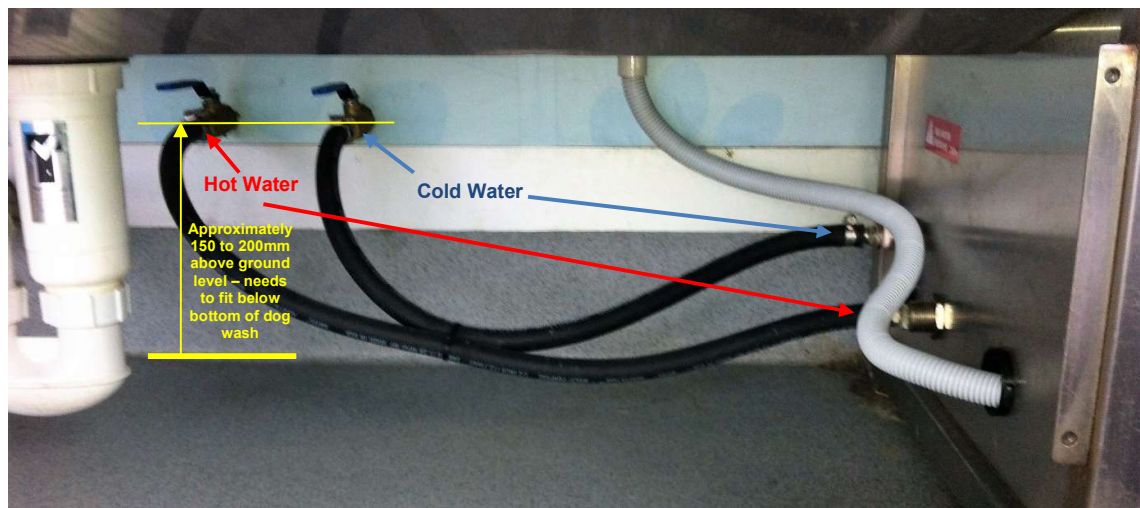

2.2.2.2 On Board Instantaneous Hot Water Unit

The picture below is the actual Stiebel Eltron DHCE 8/60 hot water unit which is fitted inside the dog wash cabinet.

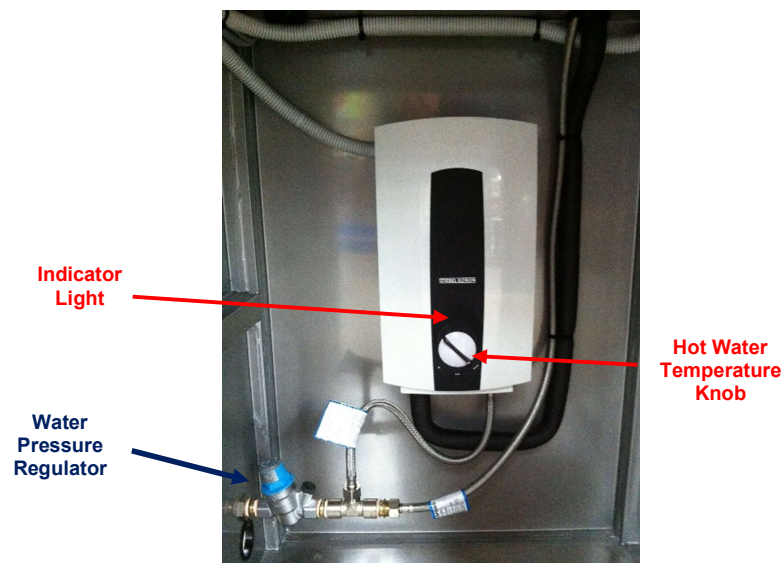

The DHCE 8/60 fully electronic instantaneous water heater heats the water while it is flowing through the unit. The indicator light will show when the heater is operation.

The heating level is set at Tru Blu to a level of 3, do not adjust the temperature level on the instantaneous water heater. To adjust the water temperature, use the tempering valve, refer to section 7.1 Temperature Valve Adjustment.

2.2.2.2.1 Initial Start Up of the Stiebel Eltron DHCE 8/60 AU Hot Water Unit

The initial start-up of the Stiebel Eltron should be conducted by an electrician referencing the Stiebel AU Operation and Installation guide.

2.2.3 On Board Hot Water Storage Unit - Breaker

After the water is connected the hot water tap is to be turned on and the hot water system filled and bled.

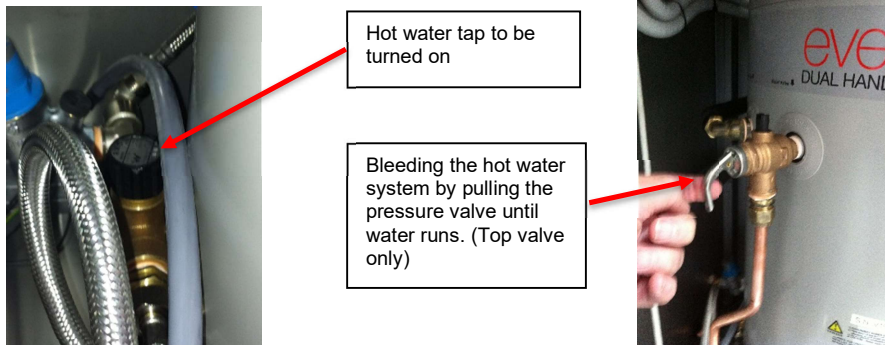

Once the hot water system is filled the hot water circuit breaker located in the control box is to be turned on. The power must be isolated prior to removing the cover from the Control Module refer to section 4 Main Board Components.

2.2.4 Connecting the Waste

Connect the 50mm waste using the P-trap (supplied in the install kit)

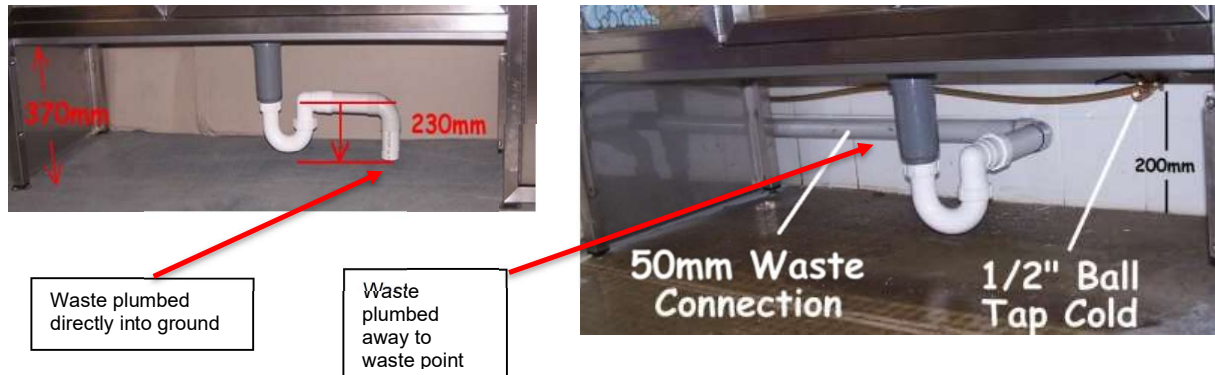

The copper waste pipe connected to the hot water unit relief valves needs to be run into a waste point or tundish (not supplied). The same waste point as the P-trap can be utilised.



Before connecting to the waste point or tundish ensure local regulations are considered as some sites may require copper pipe.

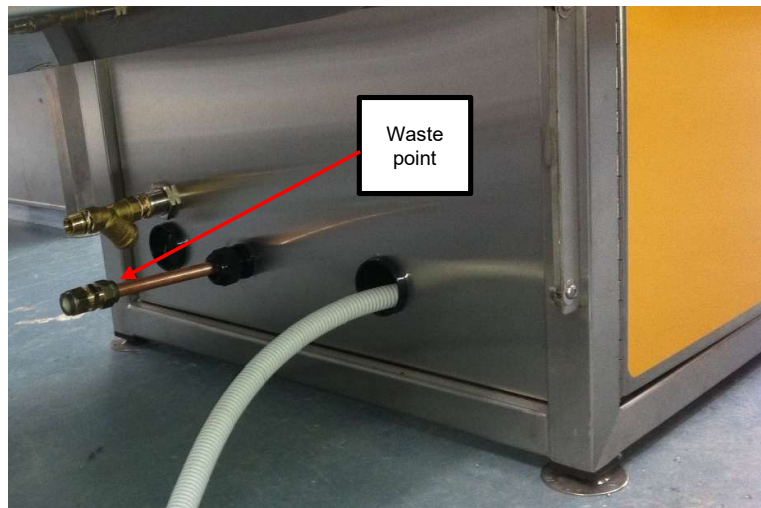

If unsure with any of the above steps please phone (03) 5562 9088 for assistance.

2.3 Connecting the Power – For Your Electrician



For CE countries there will be an isolator switch supplied with the K9000 2.0, it needs to be mounted within 1.7m from the cabinet at a height between 600mm and 1900mm from the ground. The photo below is an example. The K9000 2.0 needs to be hardwired to the switch board on its own circuit the size of the circuit depends on the specification of the K9000 2.0 Refer to the rating plate located inside the cabinet to see your max load. This circuit needs to have a standard circuit breaker on the switch board as the K9000 2.0 is protected with an RCD.

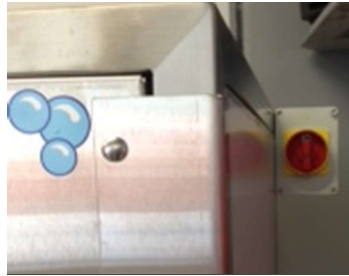

Shown on the right is the main electrical cable inside the dog wash. It enters through the gland at the bottom of the dogwash close to the ground. Run the power cable in 25mm flexible conduit as there is a socket already installed into the bottom of the main circuit breaker box shown. Leave 1m in length after you have reached the bottom gland.



Shown on the left is a photo of the main electrical cable entry point to the dog wash. Once you have run the cable and conduit to this point, THEN leave another 900mm for the termination inside the dog wash.

2.4 Completing the Installation

Now that the K9000 2.0 has been installed you can now refit the front kicker plate removed earlier to allow the installation to proceed and peel the protective white film from the unit. You are now ready to commission the K9000 2.0.

Please ensure that the hot water breaker has been turned on refer section 2.2.2.

3 Commissioning the Unit

The K9000 2.0 is delivered with sufficient product for approximately 100 washes and it is recommended that commissioning the unit occurs after installation.

Commissioning the unit requires the following tests to be undertaken;

- Override key wash (refer section 9)
- Insert Coins
- Insert Notes (if applicable)

During the tests check the following;

- water pressure gauge: when pressure gun is being utilised the pressure range should be between 20 & 30 psi and when gun is off the psi should be in the range 40 to 50 psi. Refer section 2.2.1 re regulation of water pressure.

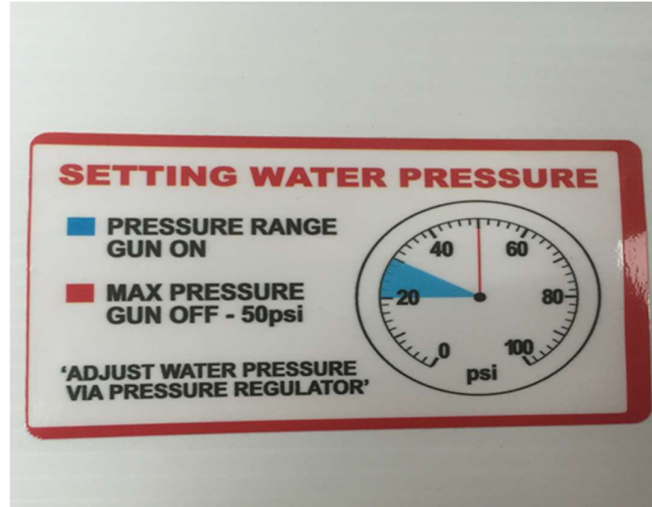

- water temperature, should be cool at a 40cm distance from the wash gun, refer section 7.1 for water temperature adjustment.

4 Main Board Components

4.1 K9000 2.0 Main Board with Iwaki EJ Series Pumps

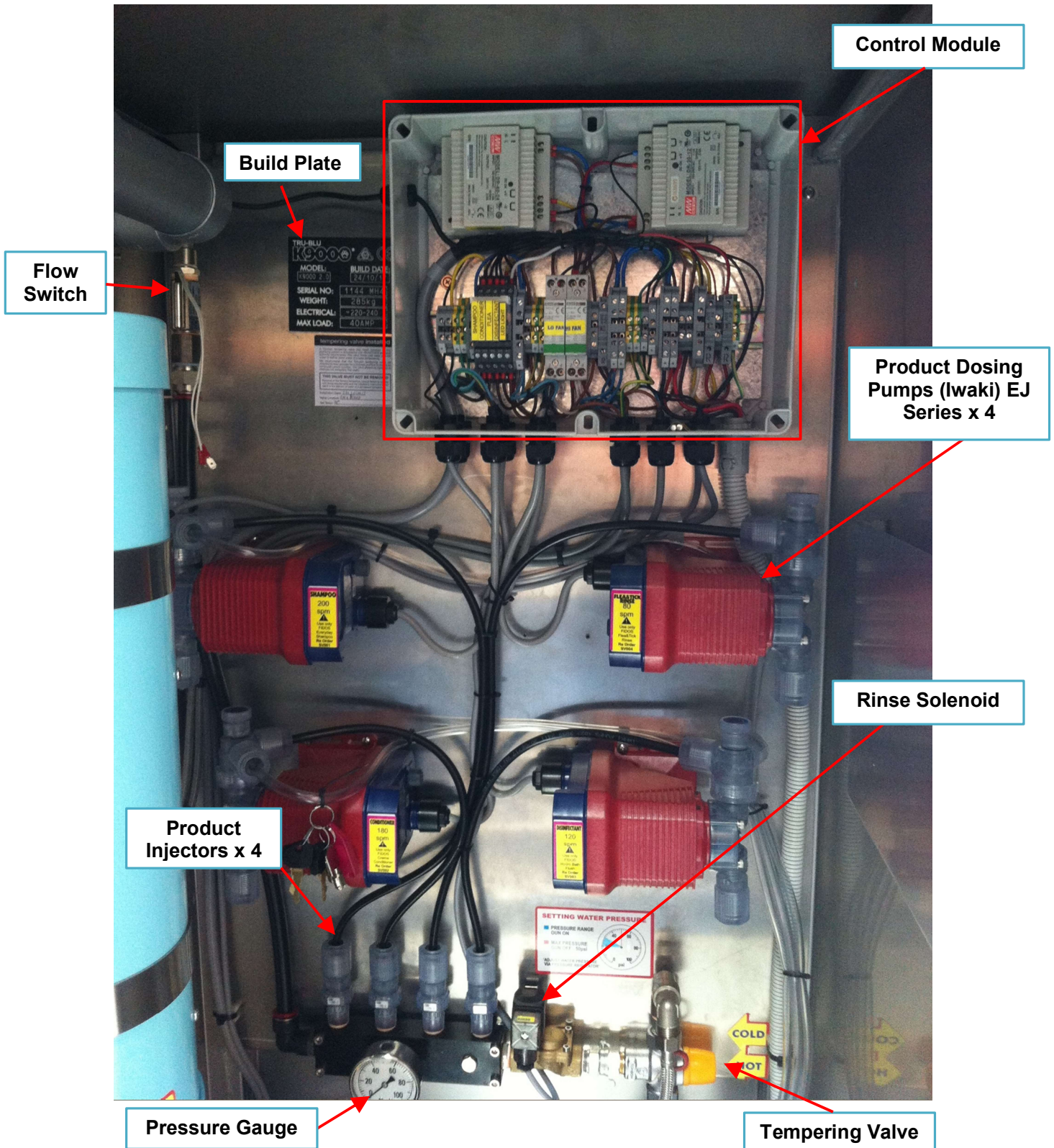

4.1.1 Control Module

The Control Module contains the fuses, transformer, relays etc.

 The cover from the Control Module should never be removed unless the power is disconnected.

The below picture has the main components of the Control Module labelled. It should be noted that there is a red LED light on each of the 3 fuses and if this is lit then the fuse has blown. To identify this, you will need to turn the power back on, but do not perform any maintenance with the power on, turn the power off once you have confirmed if a fuse has blown.

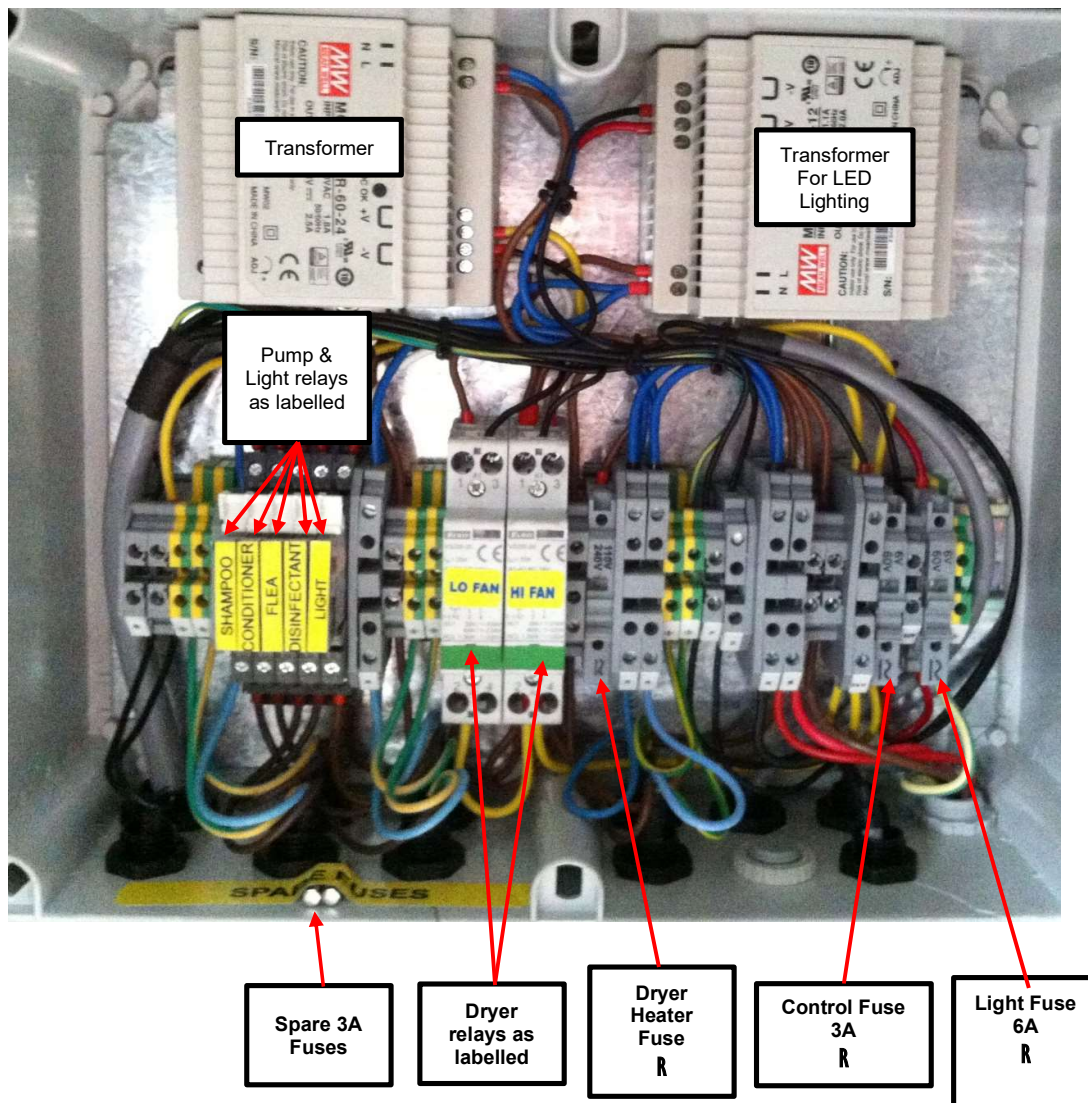

4.1.2 Product Dosing Pump Factory Settings (Iwaki EJ & ES Series Pumps)

Settings are guidelines/recommendations for Fido's products:

- Shampoo: 200 SPM*
- Condition rinse: 180 SPM*
- Flea & Tick rinse: 80 SPM*
- Tub disinfectant: 120 SPM*
- Flea shampoo (export only): 180 SPM*

*Note: Strokes Per Minute

4.1.2.1 Iwaki EJ Series Pump

To adjust settings, depress the up arrow* to the recommended SPM rate, as detailed above.

Should you be using another approved product please contact Tru Blu on 03 5562 9088 for settings.

*Note: The pump must be in operation when making an adjustment. The arrow will only increase the SPM, so to reduce the rate you must fully increase the rate to 360, release the Stroke Rate button and repress it. This will reset the SPM to 1, you can then increase to the required SPM rate. Once the required rate is reached press the start/stop button twice to save the required rate.

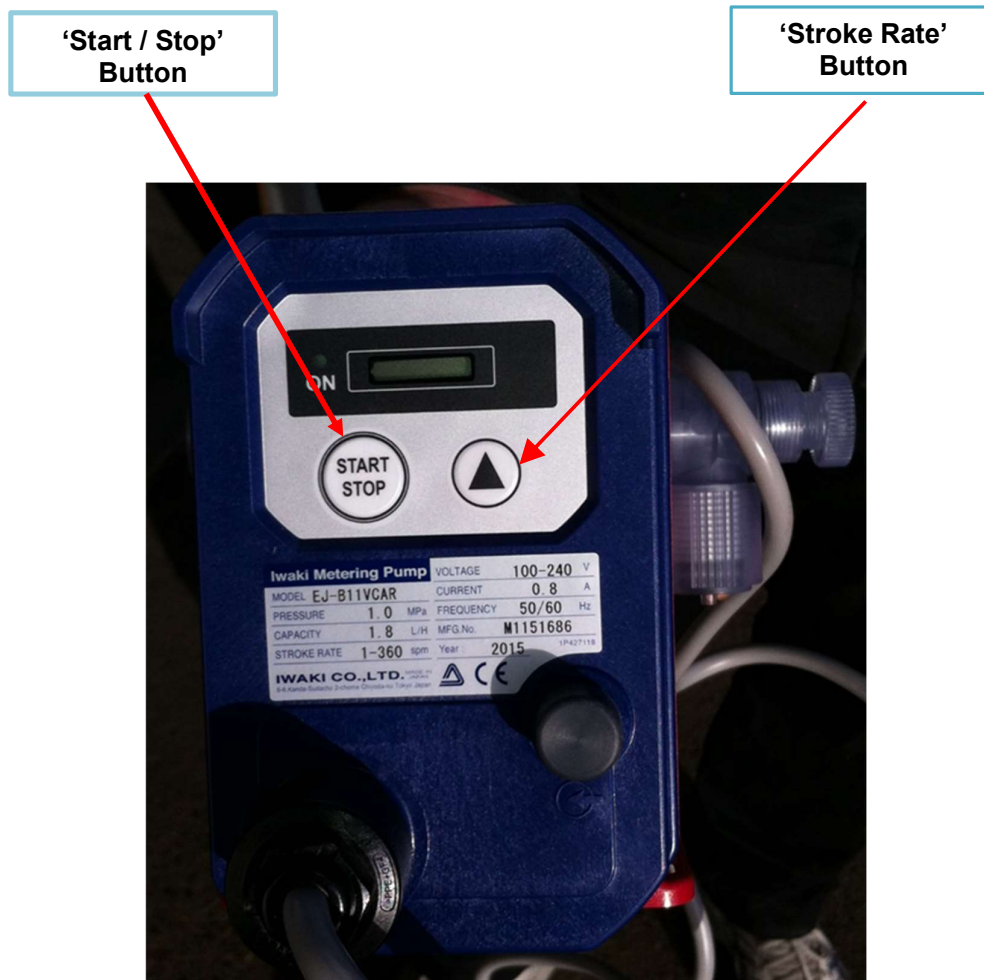

4.1.2.2 Iwaki ES Series Pump

To adjust settings, press either the up or down arrow until the recommended SPM rate is displayed, as detailed in section 4.1.2 above.

Should you be using another approved product please contact Tru Blu on 03 5562 9088 for settings.

**Note: The pump must be in operation when making an adjustment. The ES Series pump allows the operator to either increase or decrease the SPM as it has both up and down buttons. Once the rate is displayed it is saved.*

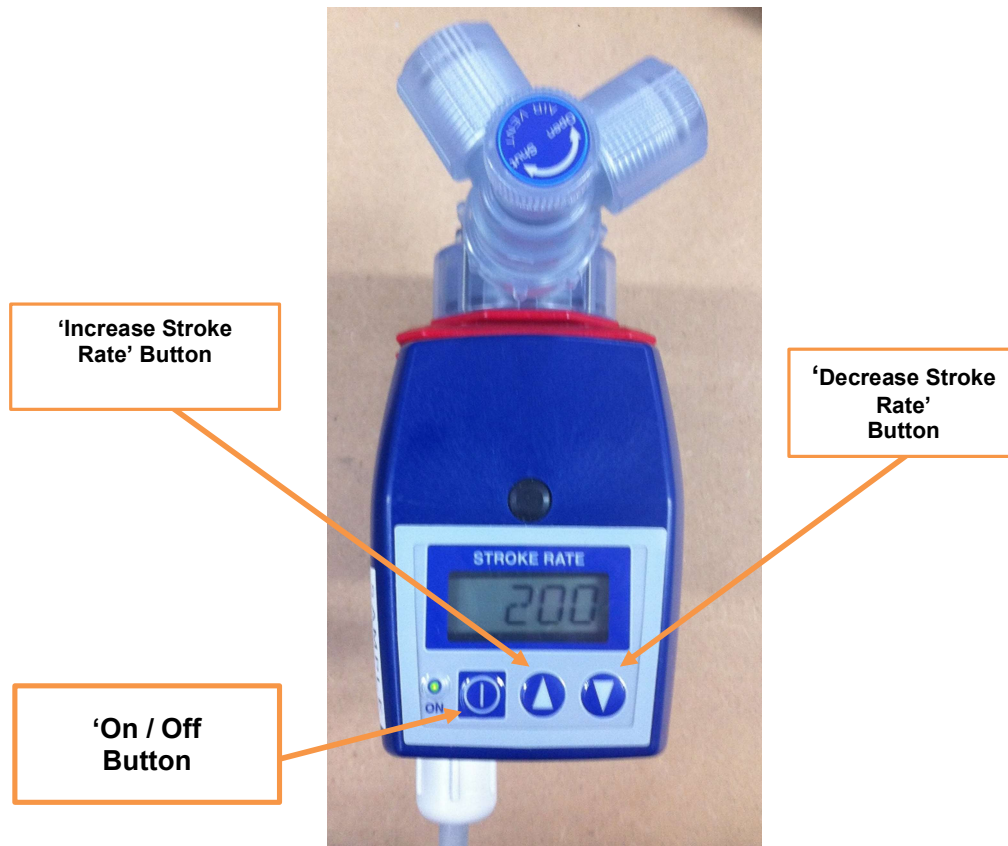

4.1.3 Bleeding Product Dosing Pumps (Iwaki – EJ or ES Series Pumps)

The need to bleed product dosing pump will arise when products have run out or in some case when products have been replaced and air has become trapped in the tube.

Bleeding procedure:

1. Select the product you wish to bleed by pushing the number associated with the product on the key pad e.g. 1 for shampoo, 2 for rinse etc
2. Release bleeder valve (item A below) by turning anti-clockwise as shown below; **3 turns maximum.**
3. Once product reaches the clear waste tube (item B below) re-tighten the bleeder valve by turning clock-wise;
4. After process is complete visually inspect the suction line for air pockets, if air pockets are present repeat the process.

NOTE: After pump has been bled, there will be a distinctive change in the sound of the pump (pump will sound quieter).



If there are problems bleeding heavier concentrates rattle the suction line (item C below), and/or squeeze it to assist with shifting the product up into the pump head.

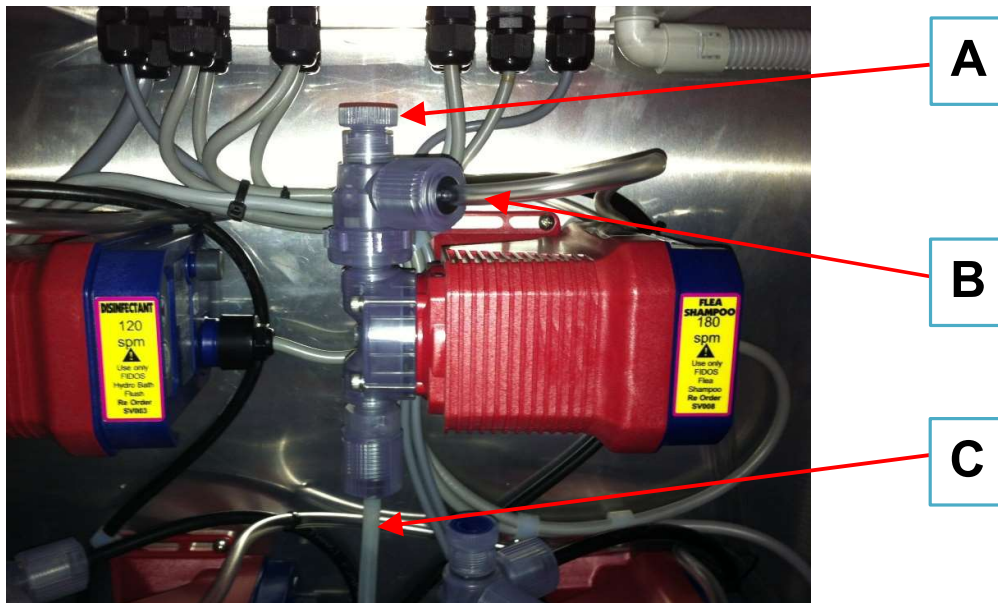

4.1.4 Iwaki Dosing Pump Exploded Views

This section has diagrams of both the EJ & ES Series pumps completely dismantled. Do not dismantle pumps beyond the extent shown in this instruction manual.

4.1.4.1 Iwaki Dosing Pump – EJ Series Exploded View

The EJ Series pump in the diagram below is completely dismantled. Do not dismantle the pump beyond the extent shown in this instruction manual.

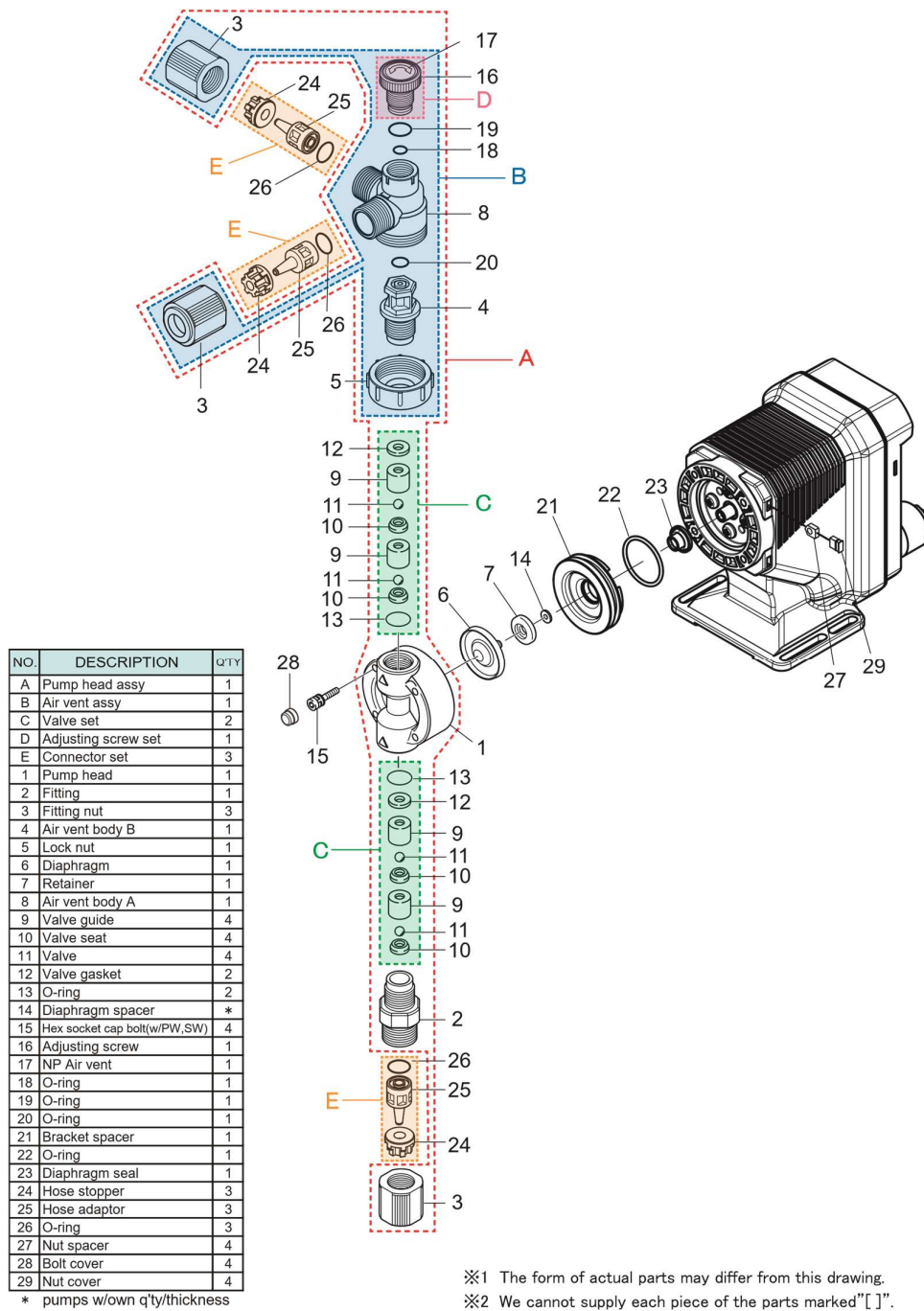

4.1.4.2 Iwaki Dosing Pump – ES Series Exploded View

The ES Series pump in the diagram below is completely dismantled. Do not dismantle the pump beyond the extent shown in this instruction manual.

Exploded view

Pump head, Drive unit & Control unit

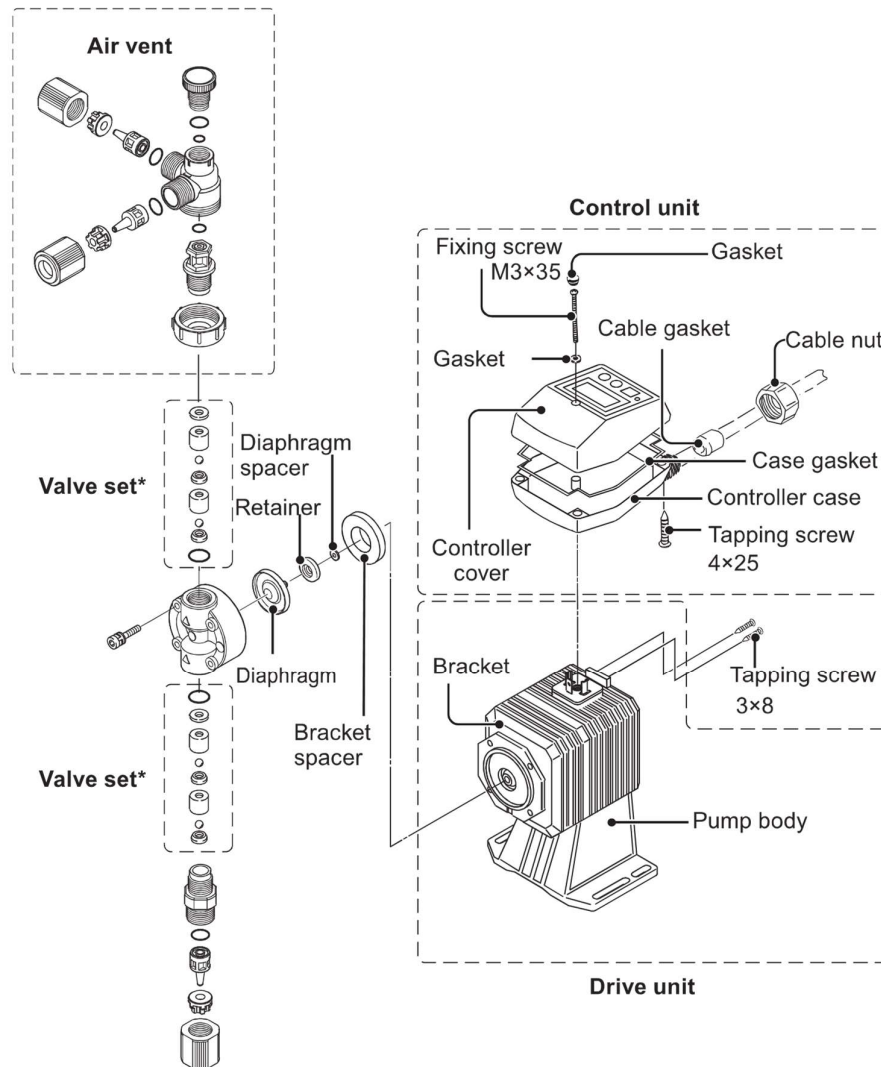

4.2 Approved Products



The only products that are approved for use in the Tru Blu K9000 2.0® Dog Wash are Fido's products produced in Australia by Mavlab Pty Ltd (www.mavlab.com.au) and those registered as a "veterinary chemical product" by the Australian Pesticides and Veterinary Medicines Authority (APVMA) for use on dogs.

The Australian Pesticides and Veterinary Medicines Authority (APVMA) contact details are:

Office: 18 Wormald Street, Symonston, ACT, 2609, Australia
Office hours: 9.00am - 5.00pm Mon - Fri EST
Mailing address: APVMA, PO Box 6182, Kingston, ACT, 2604, Australia
Email: contact@apvma.gov.au
Phone: +61 2 6210 4701
Web: www.apvma.gov.au

Q: How do I check the current registration status of a chemical product?

A: Your supplier can check the registration status of chemicals, or you can access the information on the database of all registered agricultural and veterinary products in Australia from the Public Chemical Registration Information System – PUBCRIS, accessed through the APVMA website.

Q: How do I know if a product has been registered?

A: The APVMA (known before March 2003 as the NRA) allocates a unique registration number which is printed on the bottom of the product label. The APVMA uses this approval number to verify the registration status of products. The words "*NRA Approval No.*" always appears in front of the number. The last four digits tell you when the product was last assessed by the APVMA. However, some older chemical products may not have an NRA number. In this case, ask your supplier to check that the product you want is registered.

Approved Fido's products

- | | |
|--|--|
| 1. K9000 Shampoo (Registration not req'd)
FIDOS K9000 Clear Bottled Every Day Shampoo
MSDS (see MSDS attached) | 2. Conditioner (Registration not req'd)
FIDOS K9000 Clear Bottled Crème Conditioner
MSDS (see MSDS attached) |
| 3. Flea & Tick (APVMA No. 37433)
FIDO F Rinse Concentrate
MSDS (see MSDS attached) | 4. Disinfectant (APVMA No. 57855)
Fido Hydro Bath Flush
MSDS (see MSDS attached) |

Important

The use of non-approved products may be harmful to the dog. Damage may also be caused to the Tru Blu dog wash equipment and possible voiding of the units warranty.

5 Cash Box Components

5.1 Top Section of Cash Box

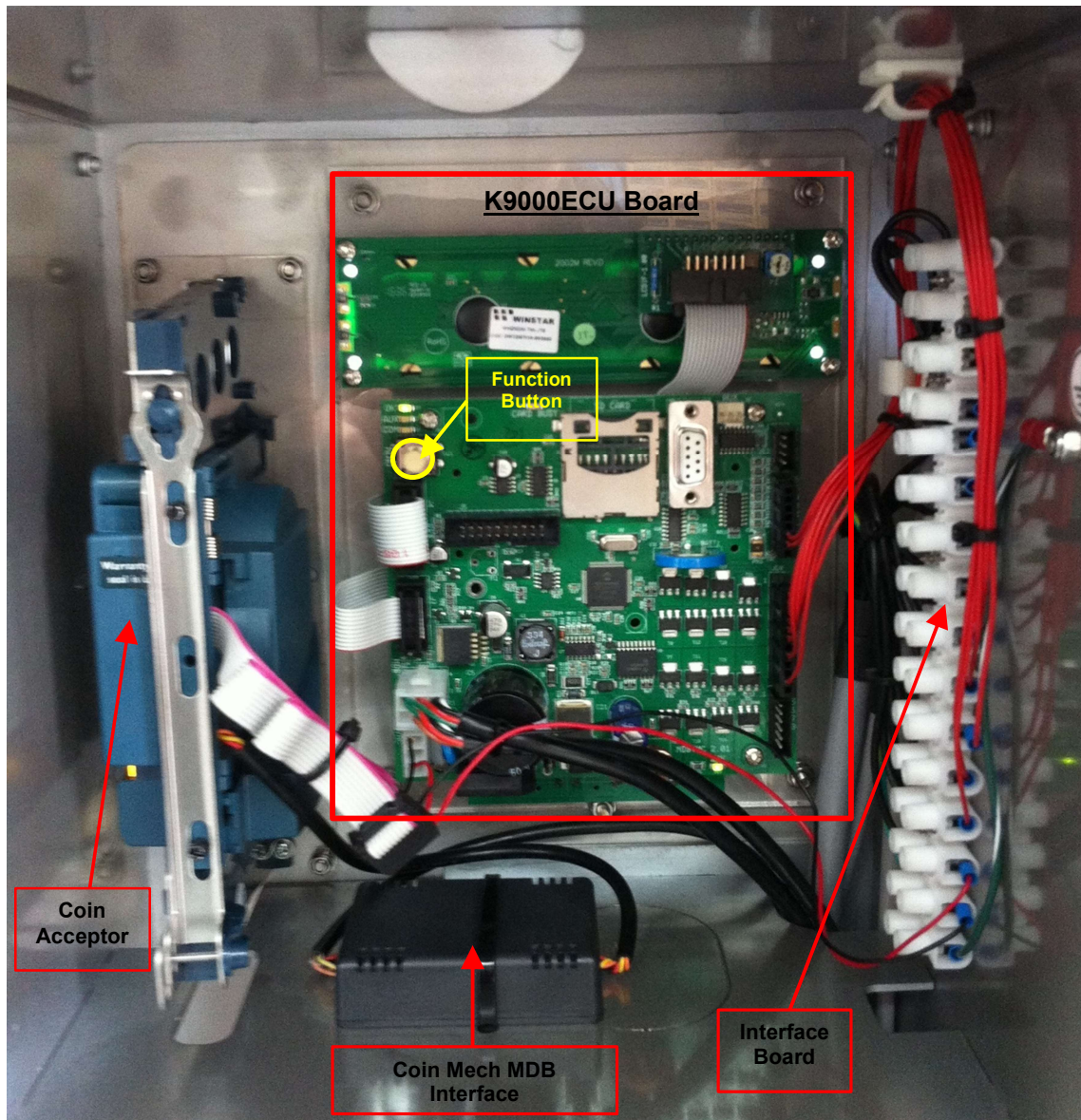

5.2 Bottom Section of Cash Box

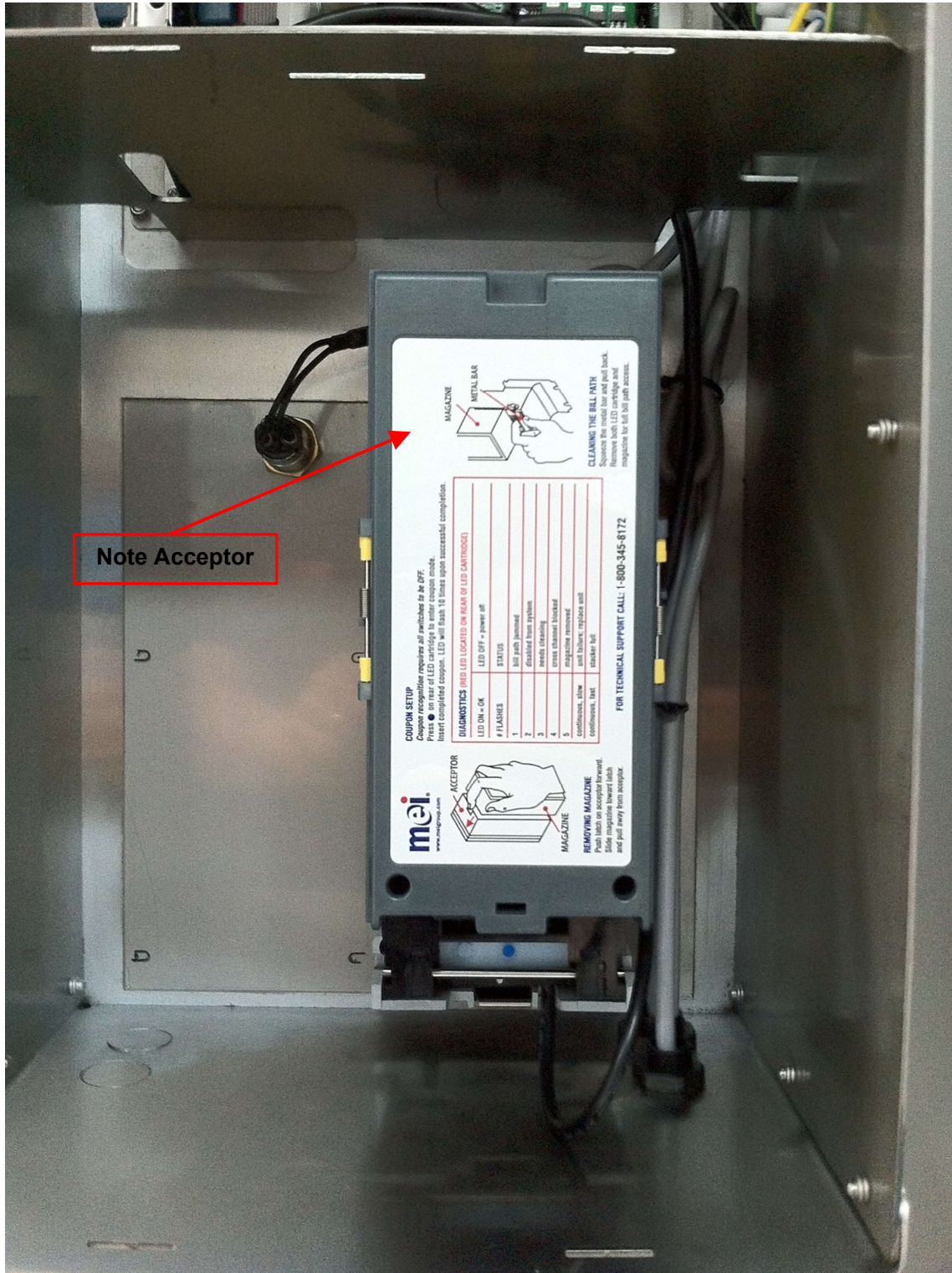

5.3 Coin Acceptor – coin activation

If the coin acceptor does not accept a coin, then it may be because the line for that particular coin is switched OFF. I.e. coin is disabled. To turn a line ON and to enable a coin, press the button once, (light will flash green) then drop the coin in. Coin should now work. To disable a coin, press the button twice, (light will flash red) then drop the coin in, coin will now not work.

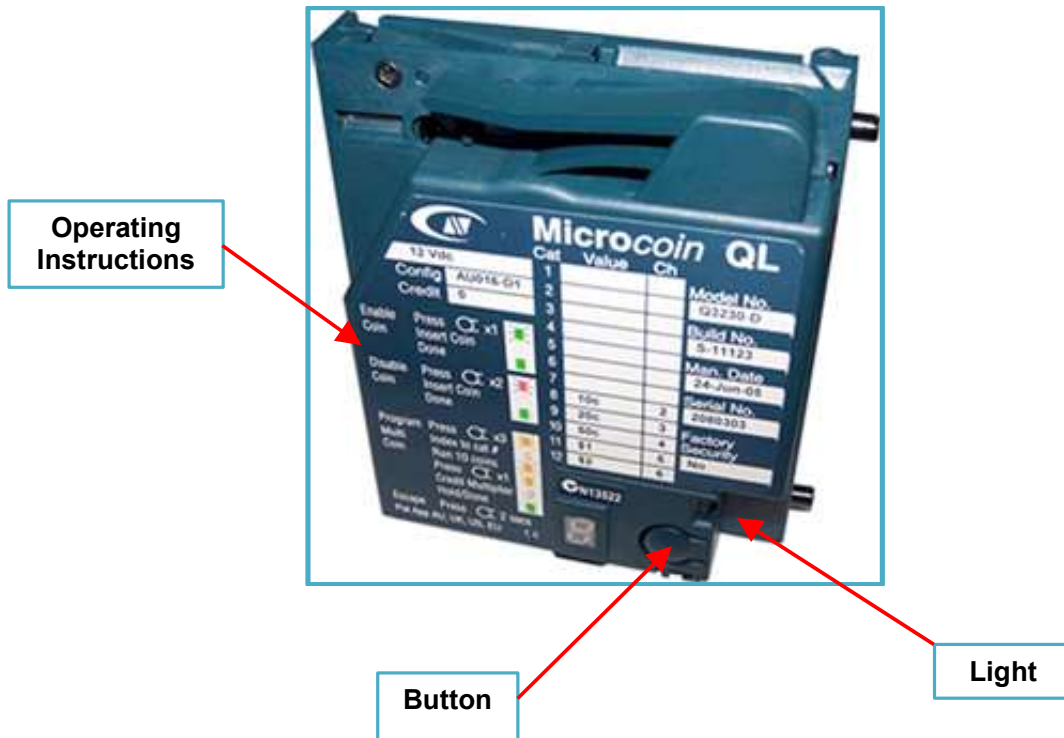























Service agent refer to -

Microsystems Controls Pty Ltd
Unit 6, 11 Robertson Place
South Penrith NSW 2750
Ph. 61+2 4731 6655
sales@microcoin.com

Coin activation Cont'd...

- The Microcoin QL-Timer can be programmed using its On-Board Programming facility (OBP).
- Each OBP feature can be accessed by a series of button presses, using the OBP programming button, which is located below the LED indicators.
- Please use a **firm** and **rapid** button press to access each Mode. You will be shown a unique “M” LED flash sequence to indicate the selected Mode.

Feature	Description	Visual Indicators
Enable Coin	Press button once. LED flashes GREEN	    M 1 2 3
	Pass the coin to be enabled through the QL. If successful, LED will go steady GREEN	    M 1 2 3
Disable Coin	Press button twice. LED flashes RED	    M 1 2 3
	Pass the coin to be disabled through the QL. If successful, LED will go steady GREEN	    M 1 2 3
Program Multi Coin	Press button 3 times LED flashes ORANGE	    M 1 2 3
	Press Button to get to required Cat number Displayed on side of unit	(1 – 12)
	Pass 10 Coins through the QL LED flashes ORANGE	 M
	After the 10 th coin or token has passed through LED will go steady ORANGE	 M
	Display should now show number “1” This is the credit multiplier, Number 1 = 1 pulse = \$1 If programming a Token to = \$10, press button until Display shows “0”	1
Press & Hold Button, LED will go steady GREEN		

5.4 Coin Acceptor – Removal



Always disconnect power before removal of unit

Open the rear door of the top cash box, the coin acceptor is mounted on the left-hand side. Shown on the right is the stainless-steel vertical clip that holds the coin acceptor in place. Push upwards on this bracket and it will slide a short distance.

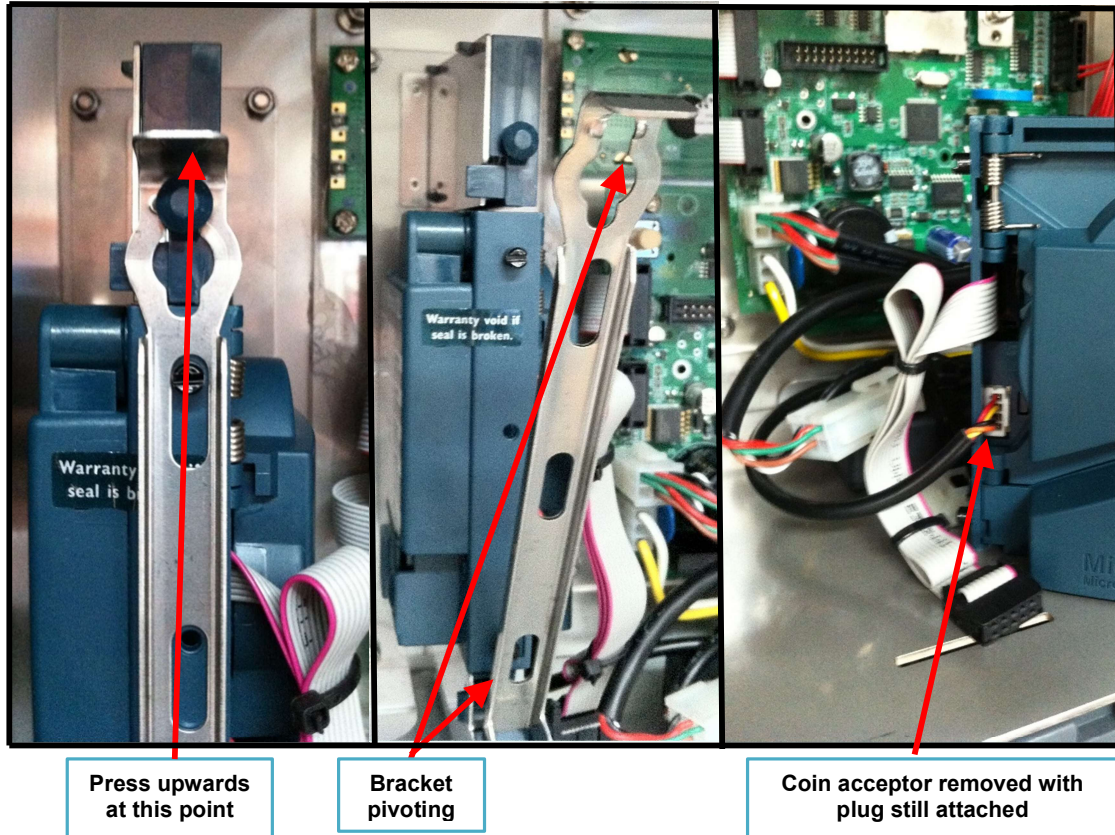

Once the bracket slides up slightly, pull it backwards towards yourself. This bracket is hinged on the bottom and will simply pivot. See middle picture

With the bracket down, the coin acceptor will slide from its mount. If possible do not disconnect the plug as the wires are delicate. If it is necessary to remove the plug use a tiny screw driver, **DO NOT PULL ON THE WIRES.**

5.5 Coin Acceptor Cleaning

Once the coin acceptor has been removed, it can be opened for cleaning.

The coin acceptor is opened as shown on the right, the side that opens is spring loaded, and will close it self when released.

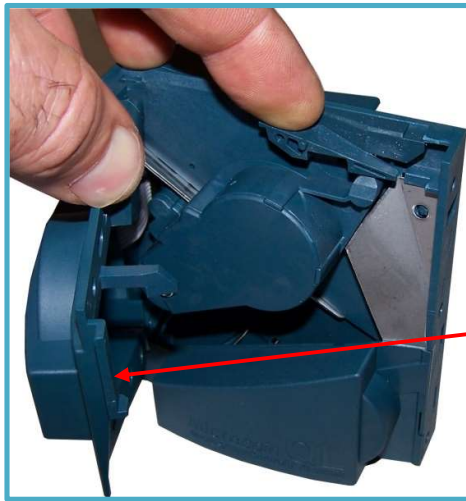
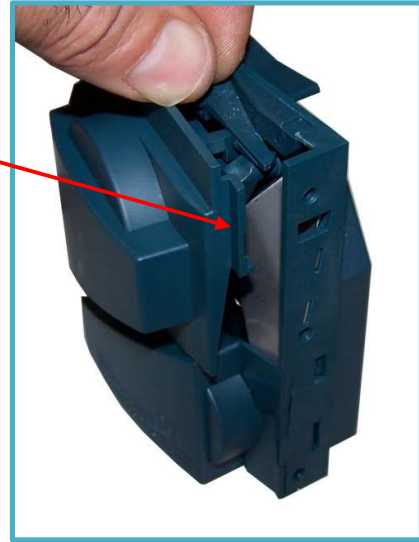

Open the side completely as shown on the left. This will allow ease of cleaning.

Using a soft damp cloth, wipe the inside area that you can see in photo on right.

Important

Do not use harsh detergents.

Once the unit has been cleaned, it is a simple case of re-inserting the unit in the reverse order that was shown on previous page.

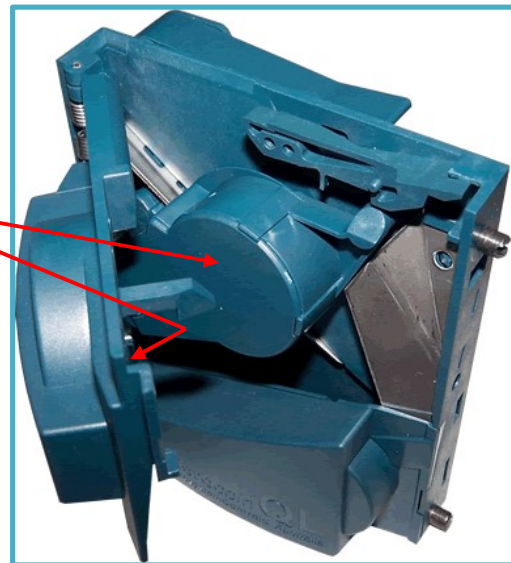

6 Note Acceptor (Mei)

6.1 Note Acceptor Fault Codes

The MEI note acceptor has built in diagnostics; this comes in the form of a flashing indicator light. The type of fault can be determined by the number of times this indicator light flashes. Below is the table to reference when trying to determine what fault the MEI note acceptor has. The label below is also stuck to the back of the note acceptor magazine.

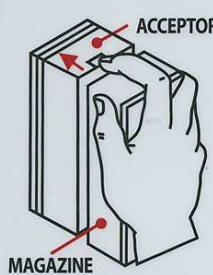

REMOVING MAGAZINE
Push latch on acceptor forward. Slide magazine toward latch and pull away from acceptor.

COUPON SETUP
Coupon recognition requires all switches to be OFF.
Press ● on rear of LED cartridge to enter coupon mode.
Insert completed coupon. LED will flash 10 times upon successful completion.

DIAGNOSTICS (RED LED LOCATED ON REAR OF LED CARTRIDGE)

LED ON = OK	LED OFF = power off
# FLASHES	STATUS
1	bill path jammed
2	disabled from system
3	needs cleaning
4	cross channel blocked
5	magazine removed
continuous, slow	unit failure; replace unit
continuous, fast	stacker full

1301 Wilson Drive
West Chester, PA 19380
PHONE: (610) 430-2500
www.meigroup.com

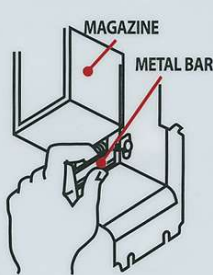

CLEANING THE BILL PATH
Squeeze the metal bar and pull back. Remove both LED cartridge and magazine for full bill path access.

FOR TECHNICAL SUPPORT CALL: 1-800-345-8172

The magazine that holds the notes must be clipped into its normal position to ensure you get an accurate fault code.

If the magazine is removed or dislodged in any way, the only fault code that you will receive will be No 5, magazine removed.



Fault code
indicating light

6.2 Note Acceptor Removal



Always disconnect power before removal of unit

To remove the note acceptor for either cleaning or servicing, first remove the note cartridge then the four small 7mm nuts need to be undone to slide the unit out of the back of the cash box. These nuts will need to be removed fully to allow the unit to come free. Once the unit is free from the mounting studs, unplug the cable from the right-hand side, you will need to slide the black cover up to unplug the cable.

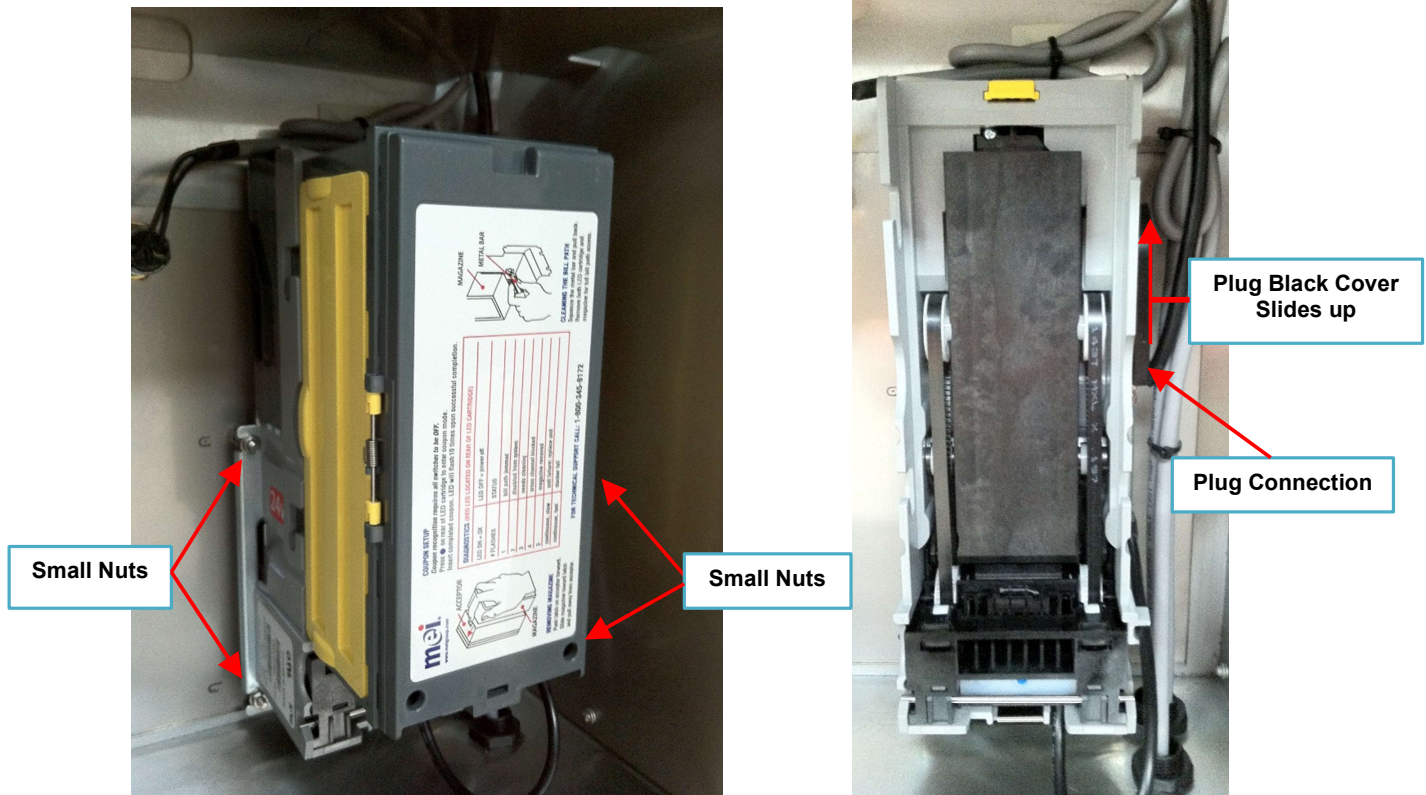

Small Nuts

Small Nuts

Plug Black Cover Slides up

Plug Connection

MARS DIP SWITCH SETTINGS FOR TRU BLU K9000

2.0

Set Switches 1, 2, 3, 4, 5, 6 & 8 to "ON"

Set Switch 7 to "OFF"

Switch 6	Harness Enable	OFF	Always Enable	ON
Switch 7	1 Pulse Per Dollar	OFF	4 Pulse Per Dollar	ON
Switch 8	Gaming/Retail Inter	OFF	Vending Interface	ON

ON
OFF

Switch 1	Bill Acceptance 1 way	ON	OFF
Switch 2	Bill Acceptance 2 way	OFF	ON
Switch 3	Bill Acceptance 4 way	ON	ON
Switch 3	High Security	OFF	High Acceptance ON
Switch 4	Accept OFF	Reject ON	\$10
Switch 5			\$20

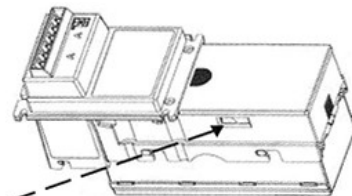

6.3 Note Acceptor Cleaning

If the note acceptor shows signs of decreased performance, it may be in need of cleaning.

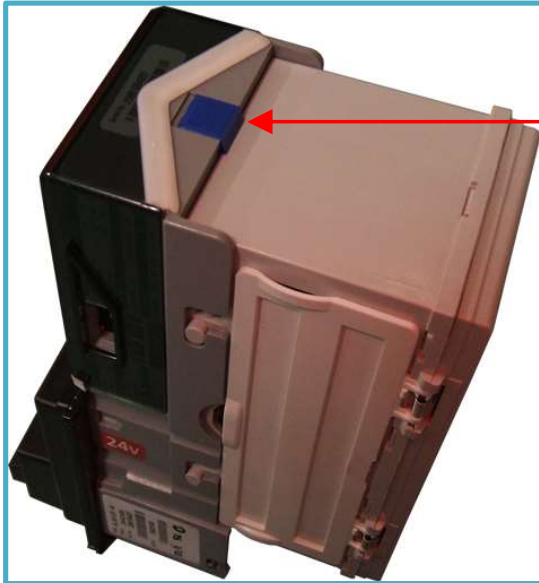

To remove the stacker from the note acceptor, press the **blue** or **yellow** catch forward and slide the rear compartment up.

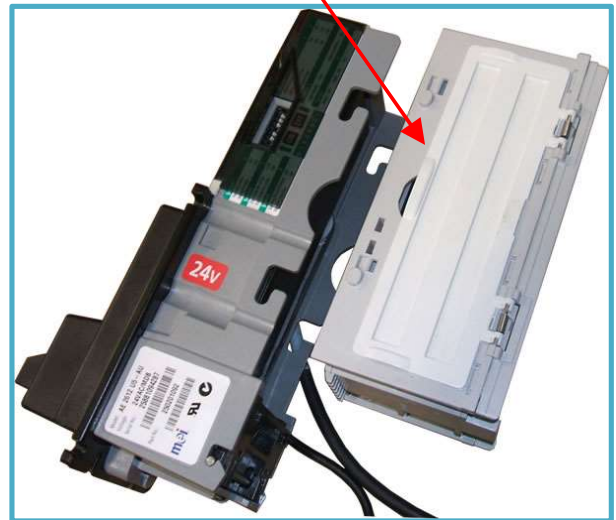

To remove the lower sensor block, raise the locator pin shown above and slide the sensor block out

Remove unit and clean with a slightly moist cloth. Pay special attention to the optical lights. Do not use harsh solvents.

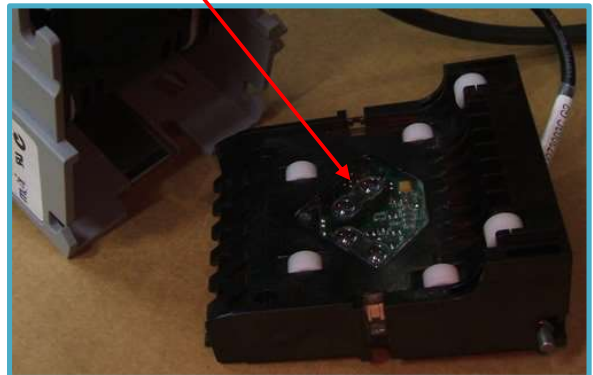

7 Temperature Valve

7.1 Temperature Adjustment

The temperature valve mixes the hot and cold water to a safe temperature. The base setting is 35°. In some instances, operators may wish to increase or decrease the water temperature slightly to compensate for seasonal changes.

Adjustment procedure:

1. Remove amber safety cap from the end of valve (picture A).
2. Undo the brass lock nut.
3. Using the amber safety cap rotate clock-wise to decrease temperature and anti-clockwise to increase temperature (picture B).
4. Re tighten the lock nut.
5. Refit amber safety cap.

NOTE: Temperature will change with the slightest adjustment. Care should be taken not to over-adjust. If in doubt check water temperature with a thermometer and DO NOT EXCEED 38°.

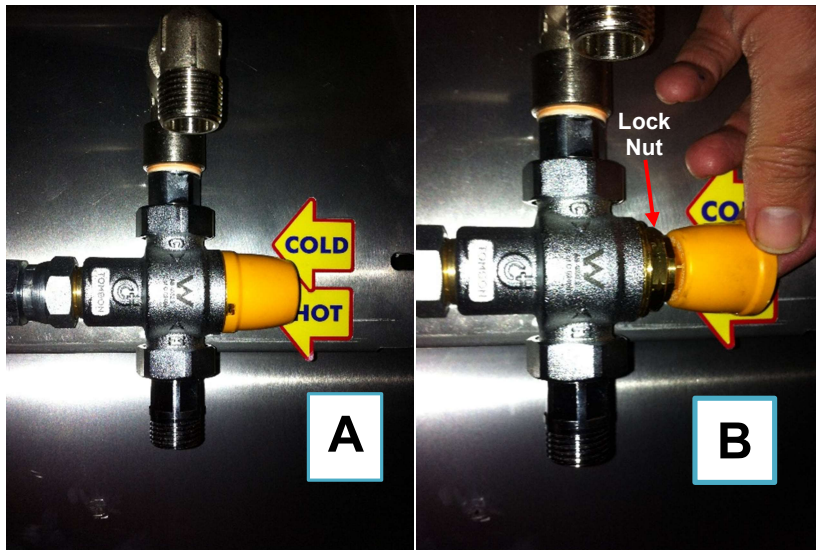

8 Dryer

8.1 By-Pass Dryer - Operation (Summer/Winter)



NOTE: Set for summer operation when the weather is consistently warm and above 30deg C (86deg F)
Set for winter operation when the weather is colder and you want the dryer to blow warmer air.
In some warmer climates, it may not be necessary to alter this tap to the winter position.
Do NOT operate the dryer in the WINTER position during hot & warm weather; this will cause distress to the dog



Set the Dryer bypass tap to the position as shown for **SUMMER** operation.

Set the Dryer bypass tap to the position as shown for **WINTER** operation. The tap is set at an angle of 45 degrees to the pipe

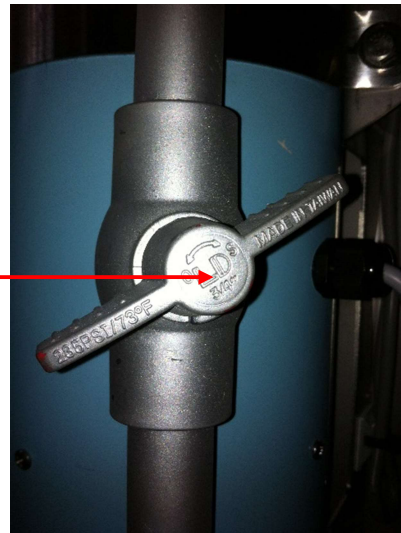

8.2 Heated Dryer - Operation (Heat Settings)

The K9000 2.0 dog wash comes equipped with an adjustable blower heat setting for drying dogs. This is controlled by a toggle switch.



Heat
Toggle
Switch

HEAT SWITCH

This toggle switch is marked with the sticker shown on the right. The setting of this switch is dependent on the temperature range the dog wash unit is being operated in. i.e. the temperature of the day.

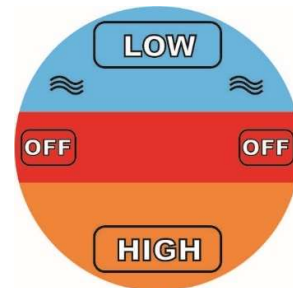

HEAT SWITCH SETTINGS

Using the picture shown on the right, set the heat switch to the appropriate position, taking into consideration the temperature range that the dog wash is operating in. The sticker shown on right is also stuck onto the K9000 2.0® dryer. Use HIGH when it is less than 5 deg, use LOW when it is 5 – 15 deg and use the OFF position when the temperature is greater than 15 deg.

HIGH SETTING NOT AVAILABLE IN HOT CLIMATES

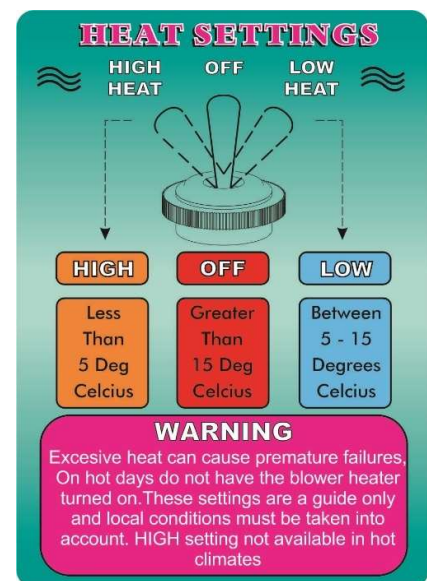

8.3 Dryer Hose Connection

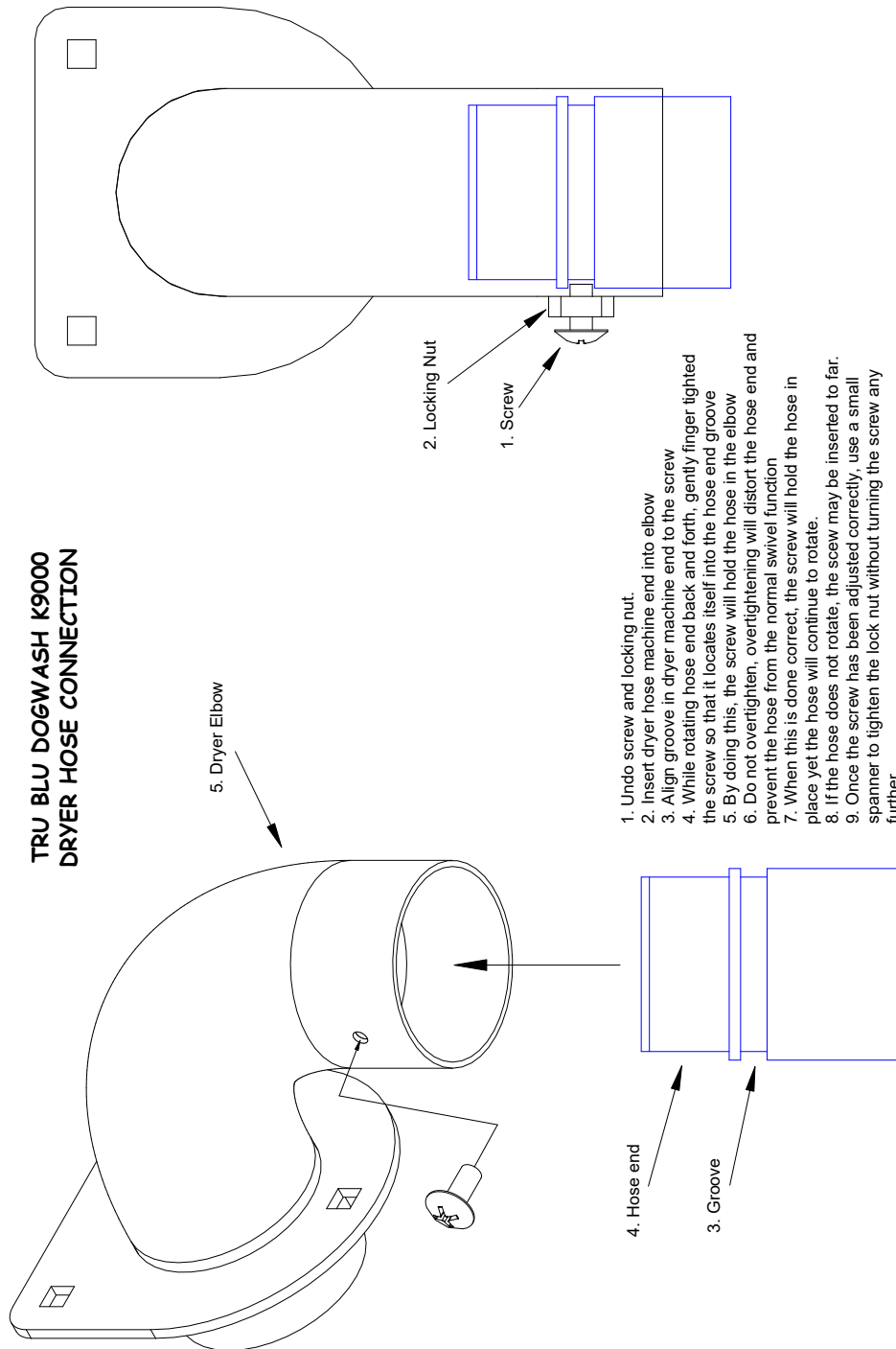

9 Override Key (Wash down Key)

The K9000 2.0® is equipped with an “OVERRIDE KEY”.

The operation of this key enables the owner/attendant to operate the wash down facility without inserting any money.

During this wash down function, all selections on the Key Pad are available except the Blow Dry Hi & Lo functions.

This wash down function is not to be used for washing dogs.

Important

Remove key after wash down is complete.



10 Dog Wash K9000ECU Board Operating & Service Menu Programming Instructions

The K9000ECU board functionality is updated via the Key Pad after pressing the white button on the K9000ECU Board and holding until a long beep is heard (2nd beep). The K9000ECU Board is located in the Top Cash Box.

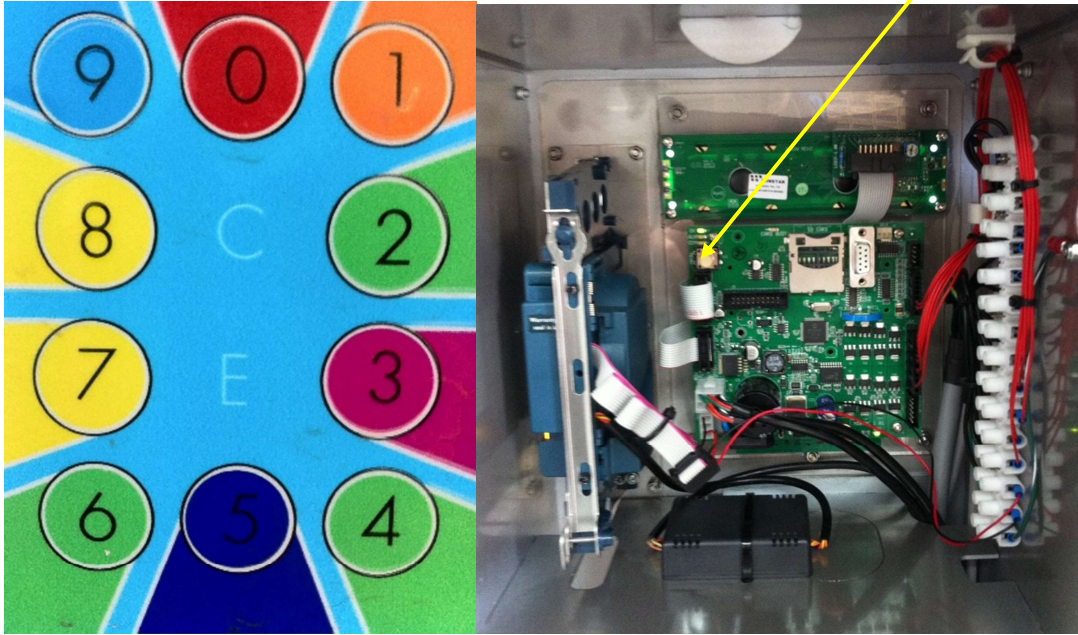

There are 6 Service Menus available for selection once the white button has been pressed:

- 1 = PROGRAM MODE *user parameters such as time, minimum \$ start up etc*
- 2 = TEST *for testing functions without inserting money*
- 3 = AUDIT *displays machines revenue, time each product used etc*
- 4 = INFO *displays K9000ECU Board information, model, version etc.*
- 5 = IMPORT *Factory use only*
- 6 = EXPORT *Factory use only*
- C = EXIT

Use the key pad to select the menu required or press C to exit the Service Menus.

The navigation processing within each menu is the same; press 2 to go to the next item, 5 to return to the previous item or C to Exit the menu.

Each item, within each menu uses the same process to be changed/added.

10.1 Service Menus

The following section lists each of the available Service Menu's along with an explanation and sample of the values of each item within those Menu's.

All site settings are pre-programmed as part of the manufacturing of the K9000 2.0.

10.1.1 Service Menu 1: PROGRAM MODE

The navigation processing within each menu is the same; press 2 to go to the next item, 5 to return to the previous item or C to Exit the menu.

Remember each item uses the same process to be changed/added, refer to section 10.1.1. *Values in blue are examples*

Press 1 To enter PROGRAM mode



- 1: DAY DATE AND TIME *THU 14/12/17 (24HR) 14:33:20*
- 2: CASH START \$ (*Minimum Cash Start-up Cost*) *10*
- 3: CASH START MINUTES *10*
- 4: CASH TOP UP \$ (*Minimum Cash Top-up Cost*) *1*
- 5: CASH TOP UP SECONDS *90*
- 6: CARD START \$ (*Minimum Card Start-up Cost*) *11*
- 7: CARD START MINUTES *11*
- 8: CARD TOP UP (*Card Top Up Amount*) \$ *4*
- 9: CARD TOP UP SECONDS *360*
- 10: GRACE TIME (Seconds the machine will allow top ups to be made after the time has elapsed, this is also the time permitted for free disinfecting the tub) *30 seconds*
- 11: MAXIMUM CREDIT (*Maximum amount of credit permitted*) *\$50.00*
- 12: MAX PAUSE TIME (*Maximum pause time per wash*) *30 seconds*
- 13: WARN TIME (*Time warning buzzer is activated prior*) *60 seconds*
- 14: START PAUSE TIME (*Number of times pause available*) *2*
- 15: LIGHT TIMER (0=OFF) (*Light time activated after wash complete, count in seconds*) *60*
- 16: LIGHT ON TIME 1 (*1st Time light comes on*) *05:00 (5am)*
- 17: LIGHT OFF TIME 1 (*1st Time light goes off*) *08:00 (8am)*
- 18: LIGHT ON TIME 2 (*2nd Time light comes on*) *18:00 (6pm)*
- 19: LIGHT OFF TIME 2 (*2nd Time light goes off*) *23:59 (11:59)*
- 20: OVERRIDE OPTIONS (*Options available via override key, i.e. to select shampoo press 1, disinfectant press 2, blow dryer low press 7, to remove an option just select option displayed i.e. blow dryer low press 7*) *RI (rinse) DI (disinfect)*
- 21: DOOR MON1 START TIME *00:00*
- 22: DOOR MON1 END TIME *00:00*
- 23: DOOR MON2 START TIME *00:00*
- 24: DOOR MON2 END TIME *00:00*
- 25: DOOR MONITOR 2 PULSE SECONDS *0:0*
- 26: HOLD C&E TO CLEAR CREDIT (s) (*To clear time remaining*) *0*
- 27: ASSET NUMBER (*Your machine asset/build number*) *9001*
- 28: MDB DEVICES= AUTO DETECT (*Runs process to identify MDB devices such as credit card, Note reader etc*)
- 29: MDB AUTO DETECT (s) (*Time (seconds) MDB detection will run for. A limit is set so search will stop if not all devices available*) *15*

10.1.2 Service Menu 2: TEST

The navigation processing within each menu is the same; press 2 to go to the next item, 5 to return to the previous item or C to Exit the menu.

Press 2 To enter TEST mode

E = RUN TEST

Press 2 again to display tests available for selection and <E> to access the tests.

1: TEST OUTPUTS <E> TEST OUTPUTS MAKE A SELECTION

This allows you to test all functions of the dog wash, **but it is critical that the wash gun is on prior to and while running any product through the pumps. If this does not occur extreme pressure will build up and will cause damage.**



2: TEST SWITCH INPUTS <E> SOLD OUT SW1 SW2

1YYYYYY6 N N

This switch tests advise if the Door Switch (1st Alpha Character), Flow Switch (2nd Alpha Character) and Test Over Ride Key (3rd Alpha Character) circuits are open (Y = off) or closed (N = on). In the above example all 3 switches are open (off).

3: TEST BUTTONS <E> This allows you to select each button on the menu and display the value on the screen if you select a button and nothing is displayed this means the button is not functioning.

10.1.3 Service Menu 3: AUDIT

The navigation processing within each menu is the same; press 2 to go to the next item, 5 to return to the previous item or C to Exit the menu.

The Audit Menu items either count numbers, dollars or time for each item. Please note you may not use all items available for the audit process.

Press 3 To enter AUDIT mode

- 1: ITEMS SOLD 0 (*Payments Made*)
- 2: TOTAL SOLD \$0.00
- 3: ITEMS FREE 0
- 4: TOTAL FREE \$0.00
- 5: ITEMS TOKEN 0
- 6: TOTAL TOKEN \$0.00
- 7: ITEMS CASHLESS 0
- 8: TOTAL CASHLESS \$0.00
- 9: TOTAL COINBOX \$0.00
- 10: TOTAL NOTES \$0.00
- 11: RINSE M:SS 0.00
- 12: SHAMPOO M:SS 0.00
- 13: CONDITIONER M:SS 0.00
- 14: FLEA M:SS 0.00
- 15: DISINFECT M:SS 0.00
- 16: DRY LOW M:SS 0.00
- 17: DRY HIGH M:SS 0.00
- 18: OVERRIDE M:SS 0.00
- 19: FAULT HISTORY (E=Detail)
- 20: DOOR ACCESS TIMES (E=Detail)
- 21: LAST RESET 00.00 XX/XX/XX

10.1.4 Service Menu 4: INFO

The navigation processing within each menu is the same; press 2 to go to the next item, 5 to return to the previous item or C to Exit the menu.

The information menu displays specific information about your dog wash, this information is factory set and can assist with diagnosis of your dog wash should there be an issue or if you are seeking a part.

- 1: MODEL (*Model of the K9000ECU Board*) [MDBVMC-DOG](#)
- 2: FIRMWARE (*Version of the program/code on the K9000ECU Board*) [2.17E](#)
- 3: SERIAL NUMBER (*Serial number of the K9000ECU Board*) [IDS001007105](#)
- 4: ASSET NUMBER (*Build number of the dog wash*) [1366](#)
- 5: MDB DEVICES = (*List of the devices available for payment*) [Coin, Note, Card etc.](#)

10.1.5 Service Menu 5: IMPORT

NOT YET IN USE

10.1.6 Service Menu 6: EXPORT

NOT YET IN USE

11 Floor Lifting Tool

The following procedure is to be used for the lifting of the floor in the Dog Wash.



Caution should be taken when raising the floor as there are pinch points between the floor and the base of the unit. Ensure tool and gloves are used.

Floor Lifting Tool

The tool shown opposite is to be used for lifting the dog wash floor when needed. It is also required that “rigger” gloves be worn when performing this task.



To lift the dog wash floor, open the dog entry door, using the tool as shown above, slide the hooked end under the front edge of the floor and slide sideways until the hooked end locates into one of the notches in the front edge, then lift.

Once the floor has been lifted sufficiently, grasp the floor's front edge with your free hand and release the tool. Ensure that you are wearing proper protective gloves, *rubber gloves are not sufficient*. If you wish to wear rubber gloves, ensure that you wear a pair of “rigger” gloves as well (double glove).



12 Operator Maintenance

The K9000 2.0 can operate in temperatures from 5- 40 degrees Celsius if you experience temperatures outside of this range check with your plumber for appropriate insulation.

To gain access to the cabinet, unlock the pad lock and open the door by using the handle. Use the override key supplied to access the dog wash functions. The below Maintenance Schedule needs to be implemented to ensure the dog wash runs at its best and complies with the warranty.

12.1 Maintenance Schedule

***DAILY:**

- Clean Dog Wash area + rinse unit with wash gun.

***MONDAY & FRIDAY:**

- Collect Money + record timer reading.
- Lift floor platform, remove hair from filter screen and rinse with wash gun. If the dog wash is indoors, perform this action every 25 dogs.
- Open cabinet, check soap levels and change if required.
- Check for air in product lines, bleed if necessary.

***WEEKLY:**

- Clean down stainless steel with INOX (WD spray), wipe with rag. Do not use abrasive cleaning products.

***MONTHLY:**

- Clean dryers, remove excess hair from bottom of foam filter, clean all surfaces (includes top & bottom).
- Clean coin mechanism.
- Clean note validator.
- Check dog restraints (chains, attachments & fittings).
- Check tub door latches.
- Flush drains, refer to cleaning section for instructions.

***3 MONTHLY:**

- Clean dryers, remove excess hair from bottom of foam filter, clean all surfaces (includes top & bottom).
- Clean coin mechanism.
- Clean note validator.
- Check dog restraints in each tub (chains, attachments & fittings).
- Check tub door latches.
- Flush drains, refer to cleaning section for instructions.
- Empty product overflow bucket.
- Check condition of product line tubes (black & clear), no kinks, tube in product tubs touch the bottom etc.
- Check wash gun operation, head rotation and swivel, replace if necessary.
- Check each of the dryer clamps, tighten as necessary.
- Check dryer hose swivel.

At the completion of the 3-monthly maintenance update the maintenance record, section 15 of this manual.

***6 MONTHLY:**

- Clean dryers, remove excess hair from bottom of foam filter, clean all surfaces (includes top & bottom).
- Clean coin mechanism.
- Clean note validator.
- Check dog restraints in each tub (chains, attachments & fittings).
- Check tub door latches.
- Flush drains, refer to cleaning section for instructions.
- Empty product overflow bucket.
- Check condition of product line tubes (black & clear), no kinks, tube in product tubs touch the bottom etc.
- Check each of the dryer clamps, tighten as necessary.
- Check dryer hose swivel.
- Replace Wash Gun.
- Check wash gun hose assembly.

At the completion of the 6-monthly maintenance update the maintenance record, section 15 of this manual.

YEARLY:

- Clean dryers, remove excess hair from bottom of foam filter, clean all surfaces (includes top & bottom).
- Clean coin mechanism.
- Clean note validator.
- Check dog restraints in each tub (chains, attachments & fittings).
- Check tub door latches.
- Flush drains, refer to cleaning section for instructions.
- Empty product overflow bucket.
- Check condition of product line tubes (black & clear), no kinks, tube in product tubs touch the bottom etc.
- Check each of the dryer clamps, tighten as necessary.
- Check dryer hose swivel.
- Replace Wash Gun.
- Check wash gun hose assembly, replace if necessary.
- Replace Dryer hose assembly.
- Using warm water flush out flush out all 4 pumps, suction lines, foot valves and the actual product containers, replace as necessary.
- Yearly service to be carried out by authorized Technician.

At the completion of the yearly maintenance update the maintenance record, section 15 of this manual.

**Note: No service replaces another meaning that if one service falls due at the same time as another, then both should be carried out. i.e. The Daily, Monday & Friday, Weekly and Monthly maintenance schedules could all be due and occur on the same day.*

12.2 External Maintenance Items

The following pictures highlights some of the external parts of the dog wash requiring maintenance.



12.3 Dryer Maintenance

Dryers need to be cleaned by hand each month to remove any hair that may have collected. Ensure you clean the bottom off the dryer as the foam filter is at the base of the dryer.



This picture highlights the 4 foam filters located at the base of the dryer that require cleaning

The internal dryer clamps should be checked every 3 months to ensure that the dryer pipes do not become loose. If either connection is found to be loose use a screw driver to tighten the screws that hold it in place.



Please note heated dryers only have the one clamp but have a screw that needs to be tightened.



12.4 Cleaning

- Put on suitable protective clothing, gloves, apron, and protective glasses.
- Use the wash down key to turn the machine on, select the rinse option on the Key Pad and wash the tub area of the dog wash using the dog washing gun, rinse all the excess under the edge of blue floor and turn the gun off.
- Lift the tilt floor and hold in place with the support rod attached under the floor.



Caution should be taken when raising the floor as there are pinch points between the floor and the base of the unit. Ensure tool used (refer section 10).

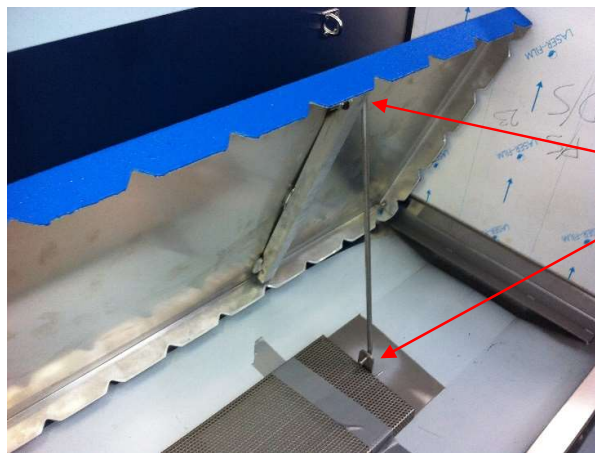

Rod attachment

- Do not remove any filters yet. Using a small plastic scoop, gather and remove the excess hair that has collected under the tilt floor area and dispose into rubbish bin. Do not flush this down any drains.
- Using the *handle* lift and remove the stainless-steel filter in the middle of the floor area, clean this of any hair or solids. Put this filter to one side.



Warning the stainless-steel filter can have sharp edges, “rigger” gloves need to be worn to protect against injury. If required, you can wear rubber gloves underneath the “rigger” gloves.

- Turn the wash gun back on and wash anything that remains in the under-floor area down the drain in the middle of the floor area, take note to wash the bottom side of the blue tilt floor. Turn gun off.
- Now remove the cylindrical filter from the drain in the middle of the floor. This simply pulls out, and has a small lip to enable removal. Empty contents into the rubbish; do not flush down any drains.



While the filter is removed, place the wash gun in the drain, set the wash gun to "JET", Key Pad selection to RINSE (option 2) and flush the drain. Run the water gun for 20 seconds, if there are issues with the water draining away you may need to contact your plumber. Replace the cylindrical filter, and put the stainless-steel filter back into position.

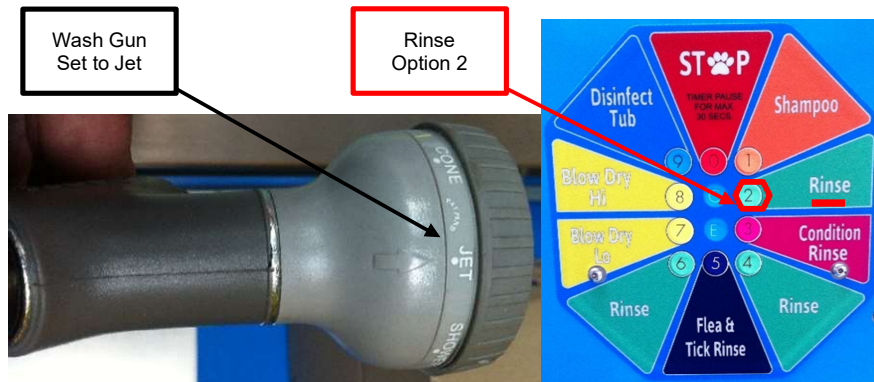

Place the wash gun in the drain press on button, you don't need to hold the gun place

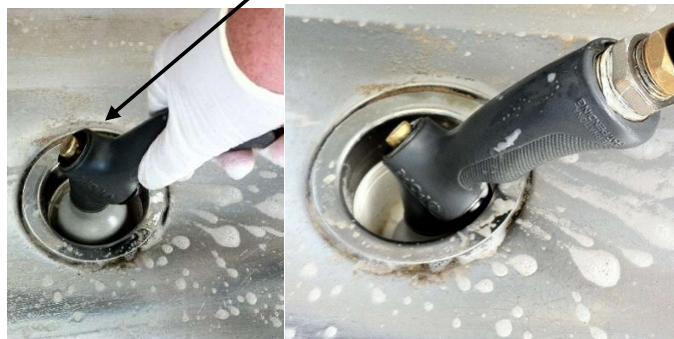

- Turn the wash gun back on, select the disinfect option (option 9) on the Key Pad and wash the under-floor area, return tilt floor to the down position. While still on disinfect, wash down the tub area of the dog wash. Turn gun off, remove wash down key and select the stop option on the Key Pad.

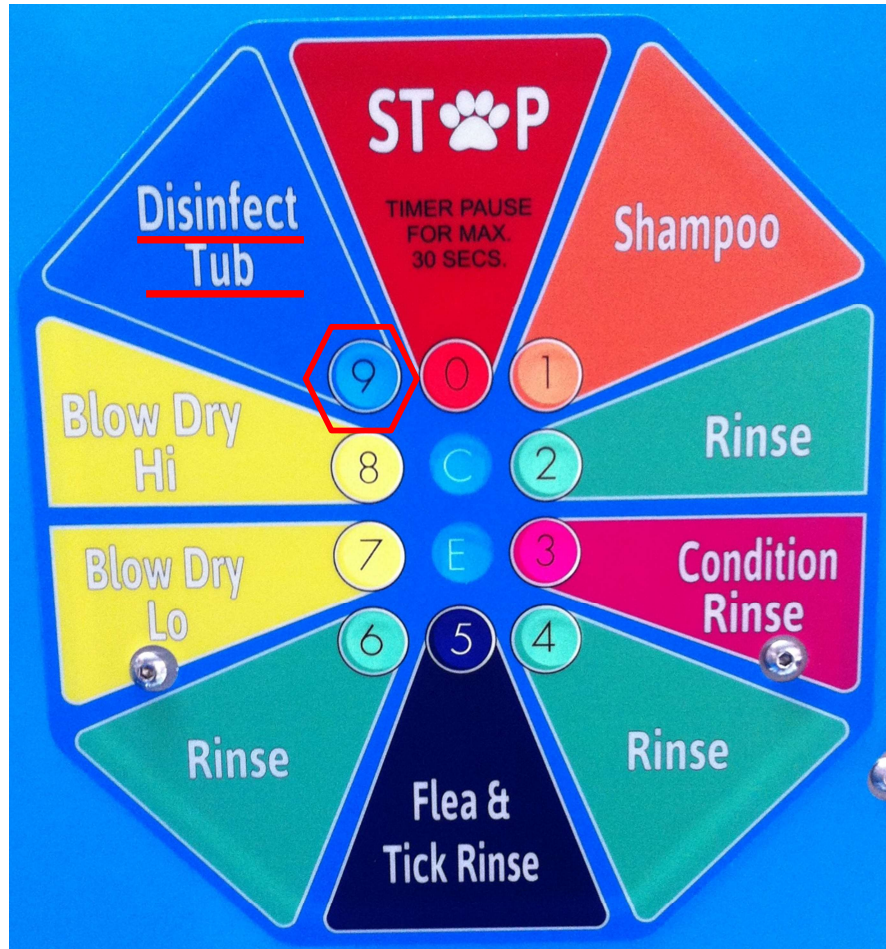

- Using soft cloth, wipe over the control panel and operator area of the dog wash. Do not use abrasive solvents.
- Clean the stainless steel by wiping down with soft cloth and INOX or WD40 spray. Do not use abrasive cleaning products and wipe down in the direction of the brushed finish.

13 General Information

It is not recommended that any person with an open wound wash a dog unless suitable protection is worn, for example if the wound is on the hand then latex or rubber gloves be worn.

It is also recommended that if a dog has broken skin it should not be washed.

13.1 Canine parvovirus



Keeping your dog wash clean.

The canine parvovirus is extremely virulent and contagious and is spread from dog to dog by direct or indirect contact with their faeces. The virus is extremely hardy and has been found to survive in faeces and other organic material such as soil for over a year. It survives extremely cold and hot temperatures. The only household disinfectant that kills the virus is bleach. Canine parvovirus will not infect humans.

If when carrying out your routine cleaning of your dog wash you discover dog faeces in or around the area, we suggest this be removed and the area disinfected with a household bleach product.

This is a very small piece of information regarding the canine parvovirus, we would strongly recommend that you familiarise yourself with more detailed information relevant to your location & situation. Useful links for further information are listed below.

http://en.wikipedia.org/wiki/Canine_parvovirus

<http://www.peteducation.com/article.cfm?c=2+1556&aid=467>

13.2 Instruction “How to Videos”

The Tru Blu K9000 website has a list of helpful videos to complement this manual, the link to the Tru Blu K9000 website is <https://trubludogwash.com.au/resources/helpful-videos/>

Videos Include:

- Your K9000 Arrives
- Introduction and Commissioning
- K9000 Dog Wash Routine Maintenance
- Setting Up Suction Lines
- How to bleed the pump on a K9000 Dog Wash
- How to bleed the new style pump
- Driving the K9000 2.0 Menu
- How to program the Timer on your Dog Wash
- How to Program the tokens on your Dog Wash
- How to change the soap on the K9000 Dog Wash

- How to change a wash gun on the K9000 Dog Wash
- How to look after the stainless steel on your K9000 Dog Wash
- How to clean your K9000 Dog Wash

14 MSDS Attachments

14.1 Material Safety Data Sheet (MSDS) Fido's Everyday Shampoo



TB-MSDS-025 Fido's
Everyday Shampoo Di

14.2 Material Safety Data Sheet (MSDS) Fido's Crème Conditioner



TB-MSDS-026 Fido's
Crème Conditioner Su

14.3 Material Safety Data Sheet (MSDS) Fido's Fre-Itch Rinse Concentrate



TB-MSDS-029 Fido's
Fre-Itch Rinse Concent

14.4 Material Safety Data Sheet (MSDS) Fido's Hydrobath Flush



TB-MSDS-028 Fido's
Hydrobath Flush Sumi

